

PPP-B-621D

October 21, 1981

SUPERSEDING

Fed. Spec. PPP-B-621C

October 5, 1973

FEDERAL SPECIFICATION

BOXES, WOOD, NAILED AND LOCK-CORNER

This specification was approved by the Commissioner, Federal Supply Service, General Services Administration, for the use of all Federal agencies.

1. SCOPE AND CLASSIFICATION

1.1 Scope. This specification, and appendix thereto, covers new nailed and lock-corner wood boxes, assembled or knocked down, for use as domestic and overseas shipping containers.

1.2 Classification.

1.2.1 Classes and styles. Wood boxes shall be furnished in the following classes and styles, as specified (see 6.2).

Class 1 - Domestic

Style 1
 Style 2
 Style 2-1/2
 Style 3 deleted
 Style 4
 Style 4-1/2
 Style 5
 Style 6
 Style 7

Class 2 - Overseas

Style 2
 Style 2-1/2
 Style 3 deleted
 Style 4
 Style 4-1/2
 Style 5
 Style 7

1.2.2 Grades. All classes and styles shall be grade B unless grade A is specified (see 6.2).

Grade A - With preservative treatment
 Grade B - Without preservative treatment

FSC 8115

PP-8-6210

1.2.3 Types of loads. The boxes shall be furnished for the shipment of type 1 (easy), type 2 (average), and type 3 (difficult) loads, as specified (see 6.1 and 6.2).

1.3 Part number. Specification part number for items described will be formulated as shown in 6.8.

2. APPLICABLE DOCUMENTS

2.1 The following documents, of the issues in effect on date of invitation for bids or request for proposal, form a part of this specification to the extent specified herein:

Federal Specifications;

FF-F-133	-	Fasteners, Wood Joint, Corrugated (Saw Edge)
FF-N-105	-	Nails, Brads, Staples and Spikes, Wire Cut and Wrought
FF-S-111	-	Screw, Wood
TT-W-572	-	Wood-Preservative; Water-Repellent

Federal Standard;

FED-STD-123 - Marking for Shipment (Civil Agencies)

(Activities outside the Federal Government may obtain copies of Federal specifications, standards, and commercial item descriptions as outlined under General Information in the Index of Federal Specifications, Standards and Commercial Item Descriptions. The Index, which includes cumulative bimonthly supplements as issued, is for sale on a subscription basis by the Superintendent of Documents, US Government Printing Office, Washington, DC 20402.)

(Single copies of this specification, other Federal specifications, standards, and commercial item descriptions required by activities outside the Federal Government for bidding purposes are available without charge from General Services Administration Business Service Centers in Boston; New York; Washington, DC; Philadelphia; Atlanta; Chicago, Kansas City, MO, Fort Worth; Houston; Denver; San Francisco; Los Angeles; and Seattle, WA.)

(Federal Government activities may obtain copies of Federal specifications, standards, and commercial item descriptions, and the Index of Federal Specifications, Standards and Commercial Item Descriptions from established distribution points in their agencies.)

Military Standards,

MIL-STD-105	-	Sampling Procedures and Tables for Inspection by Attributes
MIL-STD-129	-	Marking for Shipment and Storage
MIL-STD-731	-	Quality of Wood Members for Containers and Pallets

(Copies of military specifications and standards required by contractors in connection with specific procurement functions should be obtained from the procuring activity or as directed by the contracting officer.)

2.2 Other publications. The following documents form a part of this specification to the extent specified herein. Unless a specific issue is identified, the issue in effect on date of invitation for bids or request for proposal shall apply:

American National Standards Institute (ANSI) Standard:

MH15.1 - Glossary of Technical Term

(Copies of the standard including the glossary are available for a fee at the American National Standards Institute Inc., 1430 Broadway, New York, NY 10018.)

National Motor Freight Traffic Association, Inc., Agent

National Motor Freight Classification

(Application for copies should be addressed to the American Trucking Associations, Inc., Traffic Department, 1616 P Street, N.W., Washington, DC 20036.)

Uniform Classification Committee, Agent

Uniform Freight Classification

(Application for copies should be addressed to the Uniform Classification Committee, Room 1106, 222 South Riverside Plaza, Chicago, IL 60606.)

STD. 20-70 American Softwood Lumber Standard

(Application for copies should be addressed to the Superintendent of Documents, U.S. Government Printing Office, Washington, DC 20402.)

(Technical society and technical association specifications and standards are generally available for reference from libraries. They are also distributed among technical groups and using Federal agencies.)

3. REQUIREMENTS

3.1 Materials. Materials shall conform to the documents referenced herein, or as specified (see 6.2).

3.1.1 Wood. Lumber shall conform to the requirements of MIL-STD-731 or in accordance with table IA as specified (see 6.2).

3.1.1.1 Tight or intergrown knots. No tight knot, tight knot cluster, or group of tight knots, within a length equal to the width of the piece of lumber in which they occur, shall have a diameter or sum of diameters, measured across the width of the piece of lumber, greater than one third the width of the piece of lumber, or 4 inches whichever is less. Season checking of intergrown knots is allowed.

3-621D

3.1.1.2 Loose or encased knots. Any loose knot, as long as it falls within the size limitations for tight knots, may by the insertion of one or more corrugated fasteners driven equally into the knot and adjacent wood, be considered a tight knot. The splitting of the knot, other than point of insertion, by the insertion of the corrugated fastener will be cause for rejection. Loose knots or holes will be permitted when occurring beneath a cleat or batten, provided that the specified nailing can be accomplished without passing through the hole or knot.

3.1.1.3 Split limitations. Exceptions to split limitations of MIL-STD-731 shall be as specified herein.

3.1.1.3.1 Width of piece from split 1-1/2 inches or greater. Splits extending the entire length of the piece will be permitted for sides, tops, and bottoms, provided the width of the piece measured from the split is 1-1/2 inches or greater, and the split is repaired with corrugated fasteners. The corrugated fasteners shall have a length and location to provide a minimum of two complete corrugations on each side of the split and shall be spaced and driven in accordance with 3.3.3.2.1 (see figures 10 (a) and (b)).

3.1.1.3.2 Width of piece from split 2-1/2 inches or greater. When the width measured from the split to the edge, as defined in 3.1.1.3.1, is 2-1/2 inches or greater, the resulting unjoined member may be considered a piece as defined in 3.3.4, provided the required nailing is accomplished (see 3.3.6.2 and figure 10 (c)).

3.1.1.3.3 Splits less than entire length of piece. Splits extending less than the entire length of the piece will be permitted for sides, top, bottom, and ends, provided that the split terminates more than 1-1/2 inches from both the side edge and end of the piece and is repaired in accordance with 3.3.3.2.1 (see figure 10 (d)).

3.1.1.3.4 Splits not exceeding 3 inches in length. Splits not exceeding 3 inches in length, provided they do not pass through a nail hole, are permitted. Splits that pass through a nail hole, which are not adjacent to the edge of the piece, and do not exceed 3 inches in length, are acceptable, provided the split does not terminate in the edge of a piece and correction is made by additional nailing (see figure 10 (f)). Splits adjacent to the edge of a piece which extend through a nail hole are acceptable, provided the split does not exceed 1 inch in length and does not terminate in the edge of the piece (see figure 10 (e and f)).

3.1.1.4 Moisture contents. Moisture content of wood components shall be as specified for pallet members in MIL-STD-731, or in accordance with the applicable commercial standard grading rules.

3.1.2 Nails. Nails shall conform to type II, styles 6, 7, 8, 9, 10, or 18, or mechanically driven, styles 7 or 10 of FF-N-105. Except for style 18, unclinched nails shall be cement coated or chemically etched (see 6.3).

3.1.3 Screws. Standard flat head screws shall conform to FF-S-111.

3.1.4 Corrugated fasteners. Corrugated fasteners shall be steel and shall conform to FF-F-133.

3.1.5 Other fasteners. In lieu of nails and screws, other fasteners may be used to secure top, bottom, sides, ends, cleats, or battens, provided the fasteners comply with the performance requirements of 3.3.6.5.

3.1.6 Wood preservative. Wood preservative shall conform to composition A of TT-W-572.

3.1.7 Glue. The glue used to join two or more pieces shall be one that meets the requirements of 3.3.3.1.

3.2 Box dimensions. Dimensions of the boxes shall be as specified (see 6.2). Dimensions shall be given in the sequence of length, width, and depth. The first two dimensions shall be the open face of the box. Unless otherwise specified (see 6.2), the dimensions of the box shall be the inside measurements. Unless otherwise specified, (see 6.2) a tolerance of $\pm 1/8$ inch will be permitted in the dimensions specified.

3.3 Fabrication.

3.3.1 Thickness and group category of parts. The thickness and group category of pieces used in the top, bottom, sides, and ends of boxes, and the thickness and width of cleats and battens, shall be determined from tables I, II, III, or IV, for class, type of load, weight of contents, style of box, and wood group, as applicable. Pieces shall be free of knot holes located at points of nailing and shall be free of knot holes or holes that expose the contents.

122-3 6210

TABLE I. Boxes for domestic shipment, type 1 (easy) and type 2 (average) loads; thickness of sides, tops, bottoms, and ends, and thickness and width of cleats 7/

Weight of contents	Groups I and II woods 1/				Groups III and IV woods 2/				
	Thickness of sides, tops, and bottoms	Inch	Thickness of ends	Inches	Thickness of sides, tops, and bottoms	Inch	Thickness of ends	Inches	
Not exceeding	Style of box	6/							Thickness and width of cleats 3/
Pounds									
--	50	1	3/8	1/2	1/2	1/4	1/2	1/2	--
--	50	4, 4-1/2, 5	3/8	1/2	1/2 by 2	1/4	1/2	1/2	1/2 by 1-3/4
--	50	2	3/8	3/8	3/8 by 2	1/4	3/8	3/8	3/8 by 1-3/4
--	50	6	3/8	1/2	--	1/4	3/8	3/8	--
50	100	1 4/	3/8	1	--	3/8	3/4	3/4	--
50	100	4, 4-1/2, 5	3/8	5/8	5/8 by 3	3/8	1/2	1/2	1/2 by 1-3/4
50	100	2, 2-1/2,	3/8	1/2	1/2 by 2	3/8	1/2	1/2	1/2 by 1-3/4
50	100	6 4/	3/8	1	--	3/8	1/2	1/2	--
100	250	4, 4-1/2, 5	1/2	5/8	5/8 by 3	1/2	1/2	1/2	1/2 by 2-1/4
100	250	2, 2-1/2, 7	1/2	5/8	5/8 by 3	1/2	1/2	1/2	1/2 by 1-3/4
250	400	5/ 2, 2-1/2, 7	5/8	1	1 by 3	1/2	3/4	3/4	3/4 by 2-1/4

1/ Nominal. The dressed sizes of wood shall equal or exceed the minimum sizes shown in table I of 20-70. For the purpose of this specification, reference to STD 20-70 shall be limited to the above.

2/ Thickness tolerance shall be $\pm 1/16$ inch for parts $3/8$ inch thick and thicker, except as otherwise specified in 3.3.1.1. Thickness tolerance shall be $+ 1/16, -1/32$ inch for pieces less than $3/8$ inch thick.

3/ Width tolerance shall be $\pm 1/16$ inch, except as otherwise specified in 3.3.2.

4/ Providing the boxes have one-piece solid sides of sawed lumber and contents are packed in interior containers.

- 5/ When load to be carried by the box exceeds 400 pounds, use table 11. When load exceeds 600 pounds, use table 11.
- 6/ Styles 2, 2-1/2, 4, 4-1/2 boxes. Unless otherwise specified, (see 6.2) when the inside depth of a box is 5 inches or less, end cleats shall not be used. Thickness of the ends shall be not less than the combined thickness of the end and cleat, as specified. Each side and end shall be made from one piece, except when the end is approximately square, a two-piece end may be used with each end piece of approximately equal thickness, and with the grain of each piece running at right angles to the other. Two-piece ends shall be nailed together with at least two clinched nails.
- 7/ See 6.1 for definition of type 1 and 2 loads.

TABLE IA. Commercial standards for lumber

Rules	Grade 1/ 2/		
	Construction	Light	Framing
CL 2/			
NEIMA 3/	"	"	"
NHPMA 4/	"	"	"
SPIB 5/	"	"	"
WCLB 6/	"	"	"
WWPA 7/	"	"	"
NHLA 8/	"	"	"

- 1/ Structural (str.) design values greater (12.5%) than str. No. 3, but slightly (10%) less than str. No. 2.
- 2/ Standard grading rules for Canadian lumber.
- 3/ Standard grading rules for Northeastern lumber.
- 4/ Official grading rules for Eastern white pine, Norway pine, Jack pine, Eastern spruce, Balsam fir, Eastern hemlock and tamarack.
- 5/ Standard grading rules for Southern pine lumber.
- 6/ Standard grading rules for West Coast lumber.
- 7/ Standard grading rules for Western lumber.
- 8/ Standard grading rules for National Hardwood Lumber Association.
- 9/ Wood shall be completely free of bark to prevent spread of Oak Wilt disease.

TABLE III. Boxes for overseas shipment, type 1 (easy) and type 2 (average) load; thickness of sides, tops, bottoms, and ends, and thickness and width of cleats 5/

Weight of contents	Groups I and II woods 2/				Groups III and IV woods 2/			
	Thickness of sides, tops, and bottoms	Thickness of ends	Thickness and width of cleats	Thickness of sides, tops, and bottoms	Thickness of ends	Thickness and width of cleats	Thickness of sides, tops, and bottoms	Thickness of ends
50	3/8	5/8	5/8 by 2	3/8	1/2	1/2 by 1-3/4	3/8	1/2
100	1/2	1	1 by 3	1/2	1/2	1/2 by 1-3/4	3/8	1/2
250	5/8	1	1 by 3	5/8	3/4	3/4 by 2-1/4	1/2	3/4
500	5/8	5/8	5/8 by 3	5/8	1/2	1/2 by 2-1/4	1/2	1/2
1000	1	1	1 by 3	1	3/4	3/4 by 2-1/4	3/4	3/4
250	1	1	1 by 3	1	3/4	3/4 by 2-1/4	3/4	3/4
500	1	1	1 by 3	1	3/4	3/4 by 2-1/4	3/4	3/4
1000	1	1	1 by 3	1	3/4	3/4 by 2-1/4	3/4	3/4

1/ Styles 2, 2-1/2, 4, 4-1/2 boxes. Unless otherwise specified (see 6.2), when the inside depth of a box is 5 inches or less, end cleats shall not be used. Thickness of the ends shall be not less than the combined thickness of the end and cleat as specified. Each side and end shall be made from one piece, except when the end is approximately square, a two-piece end may be used with each piece of approximately equal thickness, and with the grain of each piece running at right angles to the other. Two-piece ends shall be nailed together with at least two clinched nails.

2/ Nominal. The dressed sizes of the wood shall equal or exceed the minimum sizes shown in table I of STD 20-70. For the purposes of this specification, reference to STD 20-70 shall be limited to the above.

3/ Thickness tolerance shall be plus or minus 1/16 inch for parts 3/8 inch thick and thicker, unless otherwise specified in 3.3.1.1.

4/ Width tolerance shall be + 1/16 inch unless otherwise specified in 3.3.2.

5/ See 6.1 for definition of type 1 and 2 loads.

222-B-621D

TABLE IV. Boxes for overseas shipment, type 3 (difficult) load; thickness of sides, tops, bottoms, and ends, and thickness and width of cleats 5/

Weight of contents	Groups I and II woods			Groups III and IV woods 3/		
	Thickness of sides, tops, and bottoms 2/	Thickness of ends 2/	Inch	Thickness 2/ and width of cleats	Thickness of sides, tops, and bottoms	Thickness of ends
Exceeding	Style of box 1/	Not exceeding	Pounds	Inches	Inches	Inches
---	4, 4-1/2, 5	100	100	1	1 by 3	1/2
---	2, 2-1/2, 7	100	100	5/8	5/8 by 3	1/2
100	4, 4-1/2, 5	250	250	1	1 by 3	1/2
100	2, 2-1/2, 7	250	250	5/8	1 by 3	1/2
250	4, 4-1/2, 5	400	400	1-1/4	1-1/4 by 4	3/4
250	2, 2-1/2, 7	400	400	1	1-1/4 by 4	3/4
400	2, 2-1/2, 7	600	600	1	1-1/4 by 4	3/4
600	2, 2-1/2, 7	800	800	1-1/4	1-1/4 by 4	3/4
800	2, 2-1/2, 7	1000	1000	1-1/2	1-1/2 by 5	7/8

1/ Styles 2, 2-1/2, 4, 4-1/2 boxes. Unless otherwise specified (see 6.2), when the inside depth of a box is 5 inches or less, end cleats shall not be used. Thickness of the ends shall be not less than the combined thickness of the end and cleat as specified. Each side and end shall be made from one piece, except when the end is approximately square, a two-piece end may be used with each end piece of approximately equal thickness, and with the grain of each piece running at right angles to the other. Two-piece ends shall be nailed together with at least two clinched nails.

2/ Nominal. The dressed sizes of the wood shall equal or exceed the minimum sizes shown in table I of STD 20-70. For the purpose of this specification, reference to STD 20-70 shall be limited to the above.

3/ Thickness tolerance shall be $\pm 1/16$ inch for parts 3/8 inch thick and thicker, unless otherwise specified in 3.3.1.1.

4/ Width tolerance shall be $\pm 1/16$ inch, unless otherwise specified in 3.3.2.

5/ See 6.1 for definition of type 3 load.

3.3.1.1 variations in thickness. For groups III and IV woods variations in thickness due to machine operations will be permitted as specified below in not more than 10 percent of the pieces. Pieces 3/8 inch thick and thicker shall not deviate more than $\pm 1/8$ inch from specified thickness. Pieces less than 3/8 inch thick shall not deviate more than plus 1/8 or minus 1/16 inch from specified thickness.

3.3.2 Cleats and battens. Cleats and battens shall be single solid pieces. For groups III and IV woods variation in width of cleats and battens due to machine operations will be permitted as specified below in not more than 10 percent of pieces of each kind. Deviation shall be not more than $\pm 1/8$ inch from specified width.

3.3.3 Built-up pieces. Any piece or part used to make a box, excepting cleats, battens, and diagonals, may be built up by gluing (see 3.1.7), or fastening strips of proper thickness edge-to-edge in accordance with methods described in 3.3.3.1. When built-up pieces are used for fabrication of boxes, the thickness variations permitted in 3.3.1.1 and 3.3.2 shall apply.

3.3.3.1 Glued joints. Joining methods illustrated in figure 8 may be used in making built-up pieces. Glued multiple Linderman, glued tongued-and-grooved, and glued butted joints are permitted without reinforcement by mechanical fasteners, provided the glued joints meet the test requirements of 4.3.3.

3.3.3.1.1 Linderman joints. Two or more pieces that are Linderman-jointed, dove-tail type joint, and glued shall be considered as one piece.

3.3.3.1.2 Nonlocking joints. Two or more pieces butt-jointed and glued or tongued-and-grooved and glued shall be considered one piece, provided the joined surfaces are machined to insure full contact and are held under pressure until the glue is set sufficiently to withstand immersion in water and subsequent testing as specified in 4.3.3.

3.3.3.2 Mechanically-fastened joints. Butted joints and tongued-and-grooved joints in built-up pieces do not require gluing when made with corrugated fasteners as shown in figure 8.

3.3.3.2.1 Corrugated fasteners. At least two corrugated fasteners shall be used on each joint. In joining sides, top, and bottom, corrugated fasteners shall be placed within 6 inches of each end of the piece of lumber with spacing between corrugated fasteners, to be in accordance with table VI. If three or more corrugated fasteners are required in a joint, the fasteners shall be driven alternately from opposite sides of the piece. When the joint is tongued-and-grooved and glued, fasteners may be driven from one side and the joint does not require testing. On the ends of style 1 boxes, corrugated fasteners shall be driven not more than 3 inches from each end of lumber. Corrugated fasteners shall be driven flush with the surface or not more than 1/16 inch below the lumber surface. Sizes of fasteners required are shown in table V.

PSP P 621D

TABLE V. Size of corrugated fasteners for built-up pieces

Thickness of box parts	Size of corrugated fasteners
Inch	Inch
3/8	1/4 by 1
1/2	3/8 by 1
5/8	1/2 by 1
3/4 and 13/16	5/8 by 1
7/8 and up	3/4 by 1

Table VI. Maximum spacing between corrugated fasteners for sides, top, and bottom

Type of joint	Domestic boxes	Overseas boxes
	Inches	Inches
Tongued-and-grooved	9	8
Butt-jointed (or splits)	8	6

3.3.3.2.2 Fastenings across butted joints. Two or more pieces, 3/8 inch or more in thickness, and not less than 1-1/2 inches in width at either end, which are jointed and which are fastened with two or more corrugated fasteners in accordance with 3.3.3.2.1 shall be considered a built-up piece.

3.3.3.2.3 Fastenings across tongued-and-grooved joints. Two or more pieces, 3/8 inch or more in thickness, and not less than 1-1/2 inches in width at either end, which are tongued-and-grooved and which are fastened with two or more corrugated fasteners in accordance with 3.3.3.2.1 shall be considered a built-up piece.

3.3.4 Number of pieces in a box part. The maximum number of pieces making up a side, top, bottom, or end shall correspond to that allowed for the width of the box part up to 12 inches as specified in table VII. No single solid piece or built-up pieces shall be less than 2-1/2 inches in width across the space. For box parts exceeding 12 inches, the average width of pieces shall be not less than 3 inches.

PPP-B-6210

TABLE VII. Number of pieces in any box part

<u>Width of box part</u>		<u>Maximum number of pieces, single, solid or built-up</u>
<u>Exceeding Inches</u>	<u>Not exceeding Inches</u>	
-	2-1/2	1
2-1/2	5	2
5	7-1/2	3
7-1/2	12	4

3.3.5 Additional battens or cleats. Additional battens or cleats (see figure 12) of the same width and thickness as the cleats on the ends of the box shall be applied to sides, top, bottom, and ends when the unsupported span exceeds that given in table VIII for the thickness of the part involved. Additional cleats applied to ends shall run across the grain of the end boards and be placed equidistant between the regular cleats. Battens, applied to sides, top, and bottom, shall run across the grain of the part to which they are applied and shall be placed inside the box whenever the nature of the contents will permit. The unsupported span (see figure 12) is the distance between battens, the distance between the batten and the inside face of the end of the box, or if no battens are used, the inside length of the box or between the cleats on the ends of the box. Additional battens shall not be required when sides, tops and bottoms are each comprised of a one-piece part (see 6.4.4) minimum 3/4-inch thick.

TABLE VIII. Requirements for additional battens or cleats

<u>Thickness of end, side, top or bottom</u>		<u>Maximum length of unsupported span</u>
<u>Groups I and II woods</u>	<u>Groups III and IV woods</u>	
<u>Inches</u>	<u>Inch</u>	<u>Inches</u>
--	1/4	19
3/8	---	21
--	3/8	23
1/2	---	30
--	1/2	34
5/8	---	38
--	5/8	42
--	3/4	47
1	---	50
--	13/16	54
1-1/4	7/8	64

3-6210

3.3.5.1 Intermediate cleats. Nailing of intermediate cleats on end panels shall conform to the requirements for end cleats specified in 3.3.6.3.

3.3.5.2 Battens. Nailing of battens to side, top, and bottom panels shall conform to the requirements for end cleats specified in 3.3.6.3.

3.3.5.2.1 Interior battens. When reinforcement of a part is required according to table VIII, and the nature of the contents will permit, battens shall be used inside the box across the grain or pieces of each part, as shown in figure 12. One batten per part is attached at center, while two or more battens per part, when required, are attached at uniform intervals with respect to the interior distance between box ends.

3.3.5.2.2 Exterior battens. When battens are required and are placed on the outside of the box without skids, not less than two sets shall be attached across the sides, top, and bottom (see figure 12). Exterior battens shall be applied so that those on the top and bottom extend over the ends of the side battens. Sets of battens shall be located not less than 2-1/2 inches, nor greater than one sixth the length of the box with respect to each box end. However, that distance and the interval between sets of battens shall be not more than the maximum span specified in table VIII. Exterior battens shall be applied to boxes that require skids in the same manner as specified for internal battens except that the bottom battens shall be replaced by a skid of the same size specified in 3.3.5.4.

3.3.5.3 Diagonals. When specified (see 6.2), diagonal reinforcing members (see figure 12) shall be added to the interior or exterior surfaces of the box. When diagonals are specified for side or end panels they shall be of the same thickness and width as cleats specified in accordance with table II, III, or IV, as applicable, and shall be nailed in the same manner (see 3.3.6.3). Diagonals are not required for the boxes specified in table I. The number of intermediate battens or cleats determined to be required by table VIII, determines the number of single diagonals on each panel. Single diagonals in each of two adjacent areas of one panel shall be arranged to peak at center and bear against the upper end of the intermediate batten as shown in figure 12. Three or more diagonals in adjacent areas on one panel shall be arranged in zig-zag patterns shown in figure 12. When a 24-inch minimum strapping interval is required, the inner surface of exterior diagonals shall be notched as specified in 30.2.6.1.

3.3.5.4 Skids. Boxes (except style 7, see 3.4.7) with items packed therein, having a gross weight in excess of 200 pounds, or containers with both length and width dimensions of 48 inches by 24 inches or more and weighing more than 100 pounds shall be provided with a minimum of two skids. The skids shall measure a minimum of 2-1/2 inches high and 3-1/2 inches wide and shall be fabricated from one piece of lumber. When specified (see 6.2), the skids may be fabricated from two pieces of lumber.

As specified (see 6.2) the not inboard portion of skid ends shall be beveled at an angle of $45^\circ \pm 5^\circ$. Skids shall replace exterior battens on box bottoms when battens are required in table VIII (see 3.3.5.2.2). Skids shall be placed parallel to and extend the full width of the box and shall be positioned not closer than 2-1/2 inches nor more than one sixth the length of the box from each end of the box. The distance between skids measured between the inside edges, shall not exceed the distance between battens and when battens are not required, shall not exceed 48 inches. Additional skids, as required, shall be positioned so as to divide the distance between the end skids into units of equal length. When bolt fastening is provided for the item being packed, additional skids, as needed, shall be located on the box bottom so as to enable the item to be bolted through the skids. The skids shall be notched, as applicable, to provide clearance for either girthwise or lengthwise strapping. When 4-way fork entry is required, (see 6.2), skids shall be a minimum of 3-1/2 inches high and 3-1/2 inches wide, cut out a minimum of 2 inches, in depth and of such width as to accommodate forks and slings for handling, and may be placed lengthwise flush with the box sides. The skids shall be secured to the box by nails specified in 3.1.2. The nails shall be driven from the inside through the bottom into the skids and be clinched not less than 1/8 inch. Alternative to clinching, nails conforming to type II, style 18 of FF-N-105 may be used of such length as to penetrate a minimum of 3/4 the thickness of the skids and shall not protrude through the skid. The nails shall be arranged in two rows in a staggered pattern, with spacing between nails in each row not to exceed 6 inches. Nails shall not be located less than 1/2 inch from edge of the skid nor less than approximately 1-1/2 inches from the ends of the skid. Variation in specified thickness of skids may be $\pm 1/8$ inch and the variation in specified width of skids may be $\pm 1/4$ inch. When skids are specified and box requires two or more inside battens (see table VIII), the inside bottom battens need not be applied. However, a skid shall be attached to the outside of the box bottom placed in alignment with each side batten.

3.3.6 Nailing.

3.3.6.1 Size of nails. The size of nails for fastening sides, top, and bottom to ends and cleats, as determined by the groups of wood used and the thickness of the parts being fastened together, shall conform to table IX. If the required nail is not available, or splitting is encountered, one size smaller nail shall be used and the nails shall be spaced 1/4 inch closer than specified in table X. The nail sizes given in table IX apply to box assembly as distinguished from the attachment of cleats and reinforcing members on box parts, and as distinguished from the nailing of top and bottom parts to the sides of boxes.

222-8-671

3.3.6.2 spacing of nails. The average spacing of nails holding the sides, top, or bottom of the ends and cleats or battens shall be not greater than the values shown in table X. Each single solid piece or built-up piece in the sides, top, or bottom shall have at least two nails at each nailing end. Nail spacing given in the center column of table X is also applicable to the attachment of cleats, battens, and diagonals on box parts although additional nailing is sometimes required in accordance with 3.3.6.3.

TABLE IX. Size of cement-coated or chemically-etched cooler, sinker, and standard box nails for boxes

Species of wood	Thickness of ends or cleats to which sides, top, and bottom are nailed (Inch)										
	Exceeding	7/16	1/2	9/16	5/8	11/16	13/16	7/8	1	1-1/8	1-1/4
Not exceeding	7/16	1/2	9/16	5/8	11/16	13/16	7/8	1	1-1/8	1-1/4	--
Group I	4	5	5	6	7	8	8	9	9	10	14
Group II	4	4	5	5	6	7	7	8	9	9	12
Group III	3	4	4	5	5	6	7	7	8	9	10
Group IV (penny)	3	3	4	4	4	5	6	7	8	8	9

TABLE IX. Spacing of cement-coated or chemically-etched nails for boxes

Side of nails	Spacing when driven into side grain		Spacing when driven into end grain	
	Inches	Inches	Inches	Inches
Sixpenny or smaller	2	1-3/4	2	1-3/4
Sevenpenny	2-1/4	2	2	2
Eighthpenny	2-1/2	2-1/4	2-1/4	2-1/4
Ninepenny	2-3/4	2-3/4	2-1/2	2-1/2
Tenpenny	3	3	2-3/4	2-3/4
Elevenpenny	3-1/2	3-1/2	3	3
Twelvepenny	4	4	3-1/2	3-1/2
Thirteenpenny	4-1/2	4-1/2	4	4
Fourteenpenny				

When nails are alternately driven into end grain of end and side grain of cleat (such as nailing sides to ends in styles 2, 2-1/2, 4, 4-1/2, 5 and 7), use spacing schedule based on driving nails into end grain.

PPP-3-621D

3.3.6.3 Nailing of cleats, battens and other reinforcements. Each single solid piece or built-up piece shall be fastened to each vertical cleat or batten with not less than two nails or other fasteners (see 3.3.6.5). All nails shall pass through both the cleat and the end (or through batten and side, top or bottom) and be clinched not less than 1/8 inch, except that eightpenny nails or smaller may be clinched not more than 3/8 inch. The nails shall be driven in two parallel rows spaced alternately as in table X so that the end nails shall be not less than 3/4 inch from the end of the cleat or batten. In the case of a cleat attached to an end, at least one end nail shall be adjacent to the inside edge of the cleat. Nails shall be driven not more than 3/8 inch from the edge when cleat or batten is 2 inches or under in width, and not more than 1/2 inch when over 2 inches in width. Nailing patterns may be varied in sides, top, bottom, or ends when necessary to avoid conflict. Wherever cleats are used in the end construction, approximately one half of the nails used to secure lengthwise parts (such as top, bottom, and sides) to cleated end shall be driven into end pieces and the remainder into the cleats.

3.3.6.4 Nailing of tops and bottoms to box sides. Unless otherwise specified (see 6.2), the top and bottom shall be nailed to box sides. The size and spacing of nails driven through the top and bottom into the sides of the box shall conform to the requirements of table XI.

TABLE XI. Size of nails and spacing for nailing top and bottom to sides of boxes

Thickness of side Inches	Group I wood	Group II wood	Groups III and IV wood	Spacing	
				Inches	
				Minimum	Maximum
Under 3/4	No nailing permitted		--	--	-
3/4 thru 7/8, incl.	7d	6d	5d	6	8
15/16 thru 1-1/16, incl.	8d	7d	6d	6	8
Over 1-1/16	10d	9d	8d	8	10

3.3.6.5 Alternate fasteners. When fasteners other than nails and screws are used, the number of fastenings shall be determined by comparing their test value with those of the nails as covered in 4.4.2. The test values of the total number of fastenings proposed for use in a box member shall equal or exceed the test values of the total number of nails required for the same purpose when tested as specified in 4.2.2. Other fasteners shall be located similarly to nails in regard to the distance from the ends or edges of a box member and shall be spaced equidistance along the length of the member and staggered where possible. The distance between any two adjacent fastenings will be dependent upon the total number of fastenings required, as determined from the tests of 4.3.2.2, 4.3.2.3.1, or 4.3.2.3.2, as applicable.

3.3.6 Assembly, nailing, and fastening. Nails and other fasteners shall be driven so that neither the head nor the point will project above the surface of the wood, except for purposes of through nailing and clinching, where required. Occasional overdriving will be permitted but no nail or other fastener shall be overdriven more than 1/8 the thickness of the piece. When specified (see 6.2 and 6.7), the overdriving of nails and fasteners 1/8 the thickness of cleats shall be limited to not more than 10 percent for each box.

3.3.7 Application of screws. Screws shall be used for fastening of boxes, when specified (see 6.2)

3.3.7.1 Length of screws. Screw length shall be three times the thickness of the piece holding the head. If this length is not available, use the next shorter standard length. The gage of screws to be used shall be determined from table XII. If the required size of screw is unavailable, use next smaller gage and the spacing shall be reduced 1/4 inch from the spacing specified in table XIII.

TABLE XII. Gage of screws for different thickness of lumber and groups of wood species

Thickness of piece holding point of screw Inches	Screw gage for wood groups			
	I Number	II Number	III Number	IV Number
3/8	6	5	5	4
1/2	7	6	6	5
5/8	8	6	6	6
3/4	9	8	7	7
13/16	10	9	8	8
7/8	10	9	8	8
1	11	10	9	9
1-1/16	12	10	10	9
1-1/8	12	11	10	10
1-1/4	12	12	11	11
1-5/16	12	12	12	12

3.3.7.2 Spacing of screws. The spacing of screws for fastening sides, top, and bottom to ends and cleats shall be as specified in table XIII. When top and bottom are screwed to the sides, screws shall be placed 8 to 12 inches apart.

PPP B 621D

TABLE XIII. Average spacing of screws for boxes

Gage of screws	Spacing when driven	Spacing when driven	Spacing when only top
	into side grain ^{1/}	into end grain	of box fastened with screws
Number	Inches	Inches	Inches
7 or smaller	2	1-3/4	3
8	2-1/4	2	3-1/4
9	2-1/2	2-1/4	3-1/2
10	2-3/4	2-1/2	3-3/4
11	3	2-3/4	4
12	3-1/2	3	4-1/2

^{1/} When screws are alternately driven into end grain of end and side grain of cleat (such as nailing sides to ends in styles 2, 2-1/2, 4, 4-1/2, 5, and 7), use spacing schedule based on driving screws into end grain.

3.3.7.3 Driving of screws. Shank clearance holes shall be drilled in the pieces holding the shanks of screws. Pilot holes, drilled in the piece holding the points of screws, are required for group IV wood. Table XIV gives a guide for sizes of twist bits or drills to be used in drilling shank clearance holes and pilot holes for screws. Screws shall not be hammer-driven any further than to start threads into groups I, II, and III woods, then driven the remaining distance with a screw driver. All screws shall be driven until the head is flush with the board surface or not more than 1/32 of an inch below the surface without splitting the board.

TABLE XIV. Sizes for bits for drilling shank clearance holes and pilot holes for screws

Gage of screws	Shank clearance holes		Pilot holes for group IV woods	
	Size of twist bit	Gage of drill	Size of twist bit	Gage of drill
Number	Inch	Number	Inch	Number
4	7/64	34	1/16	52
5	1/8	31	5/64	49
6	9/64	29	5/64	47
7	9/64	25	3/32	44
8	5/32	20	3/32	40
9	11/64	16	7/64	37
10	3/16	12	7/64	33
11	13/64	7	1/8	31
12	7/32	3	1/8	30

3.3.3 preservative — ends of boxes for all of the finished wood parts of grade A boxes shall be preserved by immersing for a minimum of one minute in wood preservative conforming to composition A of WT-9-572. When boxes are to be painted, wood preservation shall be accomplished prior to application of paint.

3.3.8.1 Dryness of preservative. The box parts, when procured in the knockdown (KD) shook form, or complete box, shall after preservation, be dry as evidenced by the absence of discoloration of red oil soluble dye, when tested as specified in 4.3.4.

3.4 Box style details.

3.4.1 Style 1, no cleats. In the ends, the grain of the wood shall run in the direction of the greatest dimension. Style 1 boxes shall be limited to a height of 10 inches. The sum of the length, width and height shall not exceed 50 inches (see figure 1).

3.4.2 Style 2, four plain cleats each end, and style 2-1/2, two plain, two notched cleats each end. The ends of the cleats which run across the grain of the ends shall be not less than 1/8 inch nor more than 1/2 inch from the inside surface of the top and bottom. The sides, top, and bottom shall be flush with the outside surface of the cleats (see figures 2 and 3).

3.4.3 Style 4, two plain cleats each end. The cleats shall run across the grain of the ends and shall extend within 1/8 inch of the outside surface of top and bottom. The sides shall extend over the cleats (see figure 4).

3.4.4 Style 4-1/2, two plain cleats each end. The cleats shall run across the grain of the ends and shall extend within 1/8 inch of the outside surface of the sides. The top and bottom shall be flush with the outside surface of the cleats (see figure 5).

3.4.5 Style 5, two interior cleats each end. The cleats may be triangular or square in section, provided the cross sectional area is not less than that of the required rectangular cleats. The cleats shall run across the grain of the ends and shall extend within 1/8 inch of the inside surface of top and bottom. The sides, top, and bottom shall be flush with the outside surface of the ends (see figure 6).

3.4.6 Style 6, lock-corner construction. The joints between sides and ends of lock-corner boxes shall be glued (see figure 7).

3.4.7 Style 7, skidded base and fitted hood (see 6.5). The reinforced top, side, and end panels shall be assembled to form a hood. The skids shall be positioned across the extreme ends of bottom pieces to permit attachment of all end pieces to the skid edges. Skids shall be nominal 3 by 4 inch lumber laid flat (see figure 11).

PPP B 621D

3.4.7.1 Thickness and width of pieces. Sheathing pieces and reinforcing pieces or members for the style 7 boxes shall be of the thickness and width to that specified in tables I, II, III, and IV. The dimensions of horizontal, vertical, and diagonal reinforcing members on end and side panels shall correspond to those given in the tables for cleats and battens, respectively.

3.4.7.2 Reinforcing members in style 7 boxes. Vertical and horizontal reinforcing members, in the form of a rectangle and crossed diagonals, as applicable (see 3.4.7.5), shall be attached on interior surfaces of the prefabricated box panels. Through and filler pieces on end and side panels shall be as shown in figures 11, 11a, and 11b.

3.4.7.3 End panels. End panels are identified by the presence of vertical sheathing. The vertical pieces extend within 1/8 inch of each skid bottom. End and top panels on style 7 boxes shall be reinforced with vertical and horizontal framing members in the form of a rectangle, regardless of weight of contents or box dimensions.

3.4.7.4 Side panels. Side panels shall be reinforced with vertical and horizontal framing members in the form of a rectangle when the weight of contents exceed 250 pounds, or when the length of the side is greater than the length of the end. Intermediate filler pieces are added on end or side panels when necessary to shorten the unsupported span in accordance with table VIII.

3.4.7.5 Crossed diagonals. Crossed diagonals shall be applied to end panels within the frame of vertical and horizontal members when the inside depth of the box exceeds 36 inches. Crossed diagonals shall also be applied to side panels when depth of box exceeds 36 inches and framing members are present as added under the conditions specified in 3.4.7.4. Additional pairs of diagonals shall be added to each end or side panel when additional filler pieces are added in accordance with table VIII. Additional filler pieces and diagonals shall be added, regardless of table VIII, whenever the least angle between paired diagonals is less than 30°.

3.5 Identification. Unless otherwise specified (see 6.2), markings shall be stenciled, stamped, or printed and shall be limited to not less than 15 nor more than 36 square inches in area. The marking shall be placed on the outside of the box in the lower left corner of one side panel. The letters used shall be approximately 7/16 inch high, except that the specification number shall be in letters 1/2 to 3/4 inch high. Arrangement of these markings shall be as follows:

FED. SPEC. PPP-B-621D
 MANUFACTURER'S NAME
 MANUFACTURER'S ADDRESS

DOMESTIC OR OVERSEAS USE (as applicable)
 MAXIMUM WEIGHT OF CONTENTS _____ LBS.
 TYPE _____ LOAD

When the boxes are supplied in shook form by the container manufacturer, the first line of the identification may be changed to read.

SHOOK COMPLIES WITH FED. SPEC. PPP-B-621D

3.0 workmanship number shall be free of jagged edges and defects that may cause injury. Boxes shall be free of cracked, damaged, or broken fasteners that affect the points or heads, point of fastener projecting beyond the surface, or fasteners in the wrong location. The box shall be assembled with sides of panel boards butted, cleats flush with edge of end of panels plus or minus 1/16 inch, and side panels not projecting more than 1/16 inch beyond the end of the box. The top panel shall be flush with the outside edges of the end and side panels plus 1/16 inch or minus 1/8 inch. Subsequent shrinkage due to loss of moisture content may result in spaces appearing between panel boards, but in no case should these exceed 1/4 inch. Wood components shall vary no more than permitted tolerance. Nails shall not be bent and shall be driven so as not to cause splitting. Adjacent boards in a panel shall be matched in thickness within a maximum tolerance of 1/16 inch.

4 QUALITY ASSURANCE PROVISIONS

4.1 Responsibility for inspection. Unless otherwise specified in the contract or purchase order, the contractor is responsible for the performance of all inspection requirements as specified herein. Except as otherwise specified in the contract or order, the contractor may use his own or any other facilities suitable for the performance of the inspection requirements specified herein, unless disapproved by the Government. The Government reserves the right to perform any of the inspections set forth in the specification where such inspections are deemed necessary to assure supplies and services conform to prescribed requirements.

4.2 Quality conformance inspection. Unless otherwise specified, sampling for inspection shall be performed in accordance with MIL-STD-105.

4.2.1 Component and material inspection. In accordance with 4.1, components and materials shall be inspected in accordance with all the requirements of referenced specifications, drawings, and standards unless otherwise excluded, amended, modified, or qualified in this specification or applicable purchase document.

4.2.2 In-process testing. Tests shall be performed in accordance with table XV for characteristics specified therein. The sample unit shall be one side, top or bottom, one end, and one cleat of a box. The sample size for moisture content shall be the number of boxes indicated by the inspection level S-2 and the acceptable quality level (AQL) shall be 10.0 defects expressed in terms of percent defective. Lot size shall be expressed in terms of boxes. Test results shall be reported to the nearest percent. Failure of an individual wood element to meet requirements shall indicate a defective box. Testing for other characteristics as indicated in table XV shall be performed on five samples prior to fabrication of the end product. Failure to meet unit or average requirements, as applicable, shall be cause for rejection of the method of fastening (lateral resistance), or glue joint, respectively. In the event of failure under lateral resistance test, sample may be prepared with additional fasteners to meet requirements. When failure occurs under glue joint test, all glue joints in end item production shall be reinforced with mechanical fastenings specified in 3.3.3.2.

22 3-6-10

TABLE XV. In-process tests

Component	Characteristic	Requirement paragraph	Test method
Lumber	Moisture content	3.1.1.4	4.3.1
Fasteners	Lateral resistance	3.3.6.5	4.3.2
	Direct withdrawal resistance	3.3.6.5	4.3.2
Built-up pieces	Glued joint	3.3.3.1	4.3.3
	strength	3.3.3.1.2	

4.2.3 End item inspection.

4.2.3.1 End item material and component construction examination. The boxes shall be examined for the defects listed in table XVI. The inspection lot shall be expressed in units of boxes, box shooks or box members as applicable, offered for inspection at one time. The sample unit shall be one box, box shook or box members, as applicable. The inspection level shall be S-2. The AQL shall be 2.5 major and 10.0 total (major and minor combined) defects per hundred units.

TABLE XVI. Materials and component construction defects

Examine	Defect	Category	
		Major	Minor
Material:			
Wood	Knot holes which will expose contents	101	
	Loose knots show splitting		201
	Loose knots not securely fastened in place		202
	Any tight knot, tight knot cluster, or group of knots with a sum of diameters greater than one third the width of the piece, or exceeding 4 inches when contained in any length which equals the width of the piece	102	
	Wood damaged affecting serviceability	103	
	Split extending more than 3 inches, not secured with fasteners, as specified, or located closer than 1-1/2 inches from the end or side of piece	104	
	Split extending less than 3 inches and passes through nail hole		203
	Split passes through nail hole and terminates at edge of piece		204

(ASCE XVI) Materials and component construction defects (cont'd)

Examine	Defect	Category	
		Major	Minor
Construction	Thickness of wood members not within specified tolerance		205
	More than one piece per cleat or batten	105	
	Width of cleats not within specified tolerance		206
	Built-up pieces not glued or joined with fasteners as specified	106	
	Any piece of side, top, bottom, or end less than 2-1/2 inches wide	107	
	More than specified number of pieces per box part		207
	Interior battens not positioned as specified	108	
	Exterior battens more than 1/6 the distance in from ends		208
	Span between battens or cleats greater than specified	109	
	Width and thickness of diagonals more or less than that of cleats		209
	Diagonals not arranged as specified	110	
	Notching in diagonals missing when required	111	
	Skids	Missing when gross weight of box exceeds 200 pounds or 100 pounds when the length and width dimensions exceed 48 inches by 24 inches or more	112
Not positioned to replace exterior or interior battens when battens are specified		113	
Less than 1/6 the distance from each end (except style 7)			210
Less than full exterior length or width as applicable		114	
Intermediate skids missing when required		115	
Not secured to box as specified		116	
Length of nails not sufficient to clinch minimum 1/8 inch		117	
Alternate nail when used less than length required		118	
Nails more than 6 inches apart in rows			211
Nails less than 1/2 inch from edges of skid		119	
Nailing pattern starts less than 1-1/4 or more than 1-3/4 inches from ends of skid			212

PPP 3-6210

TABLE XVI. Material and construction defects (cont'd)

Examine	Defect	Category	
		Major	Minor
Fasteners (as applicable)	Less than two corrugated fasteners per joint		213
	Spacing between corrugated fasteners greater than specified		214
	Not type and size specified	120	
	Less than number specified	121	

4.2.3.2 End item assembly and workmanship examination. Examination of the end item for assembly and workmanship shall be in accordance with the classification of defects set forth in table XVII. The sample unit shall be one box. The lot shall be expressed in terms of boxes. The inspection level shall be S-2 and the AQL shall be 4.0 major and 10.0 total (major and minor combined) defects per hundred units.

TABLE XVII. Assembly and workmanship defects

Examine	Defect	Category	
		Major	Minor
Asssembly	Heads or points of fastener protrude above surface of wood	101	
	Fastener overdriven more than 1/8 the thickness of piece or more than 10 percent overdriving of fasteners in cleats of each box, when applicable		201
Nails	Nailing spacing not as specified	102	
	Less than two nails at each nailing end of piece	103	
	Additional nail missing when required due to split in end of piece	104	
	Nails not clinched minimum 1/8 inch when required to be clinched		202
	Nails less than 3/8 inch from edge of batten, cleat, or diagonal	105	
	End nails less than 3/4 inch from end of batten, cleat, or diagonal	106	
	Nails in cleats, battens, and diagonals not in parallel rows		203
Nail size not as specified	107		

TABLE XVIII. Assembly and Workmanship defects (cont'd)

Examine	Defect	Category	
		Major	Minor
Other fasteners	Less than number determined by test (see 3.3.6.5)	108	
Screws (when specified)	Gage and length not as specified for wood thickness	109	
	Spacing of screws not as specified		204
	Clearance holes missing	110	
Design of box	Not assembled in accordance with style specified	111	
Inside dimension	More or less than 1/8 inch tolerance	112	
Workmanship	Fasteners cracked, broken, or damaged affecting joint	113	
	Head or point projecting	114	
	Wrong location of fastener		205
	Visibly out of square	115	
	Cleats not flush with edge of end panels		206
	Side panels project beyond end of box		207
	Top panel not flush with end and side panels		208
	Wood components vary in thickness one from the other by more than allowed tolerance	116	
	Space between boards greater than specified		209
	Bent nails		210
	Wood split by nails		211
	Wood jagged	117	
Mismatch in thickness of adjacent boards in panel		212	

4.2.4 Packaging inspection. An examination shall be made to determine that the packing, and markings comply with the requirements of section 5. Defects shall be as set forth in table XVIII. The sample unit shall be one assembled box with tops bundled or crated, one knocked-down panel assembly (sides, top, bottom, and ends) in shock form, or one bundle or crate of box members (when box member is end product). The lot shall be expressed in terms of boxes or shocks. The inspection level shall be S-2 and the AQL shall be 6.5 defects per hundred units.

PE. 3-621D

TABLE XVIII. Packaging defects

Examine	Defect
Assembled boxes, shooks or box members, as applicable	<p>Top panel not placed with box, or alternatively, top panels not neatly, uniformly, and securely bundled or crated.</p> <p>Less than specified or indicated number of tops per bundle or crate, as applicable.</p> <p>Bundle or crate does not contain complete panel assembly for box shook.</p> <p>Less than specified or indicated number of panels per bundle or crate.</p> <p>Any member of box broken or damaged affecting serviceability.</p>
Marking	Omitted; incomplete; incorrect, illegible; of improper size, location, sequence, or method of application.

4.3 Methods of inspection.

4.3.1 Moisture content. For determining the moisture content of wood, the methods specified in MIL-STD-731 shall be used. When the electric moisture method specified in MIL-STD-731 is used, each individual finding shall be an average of three determinations.

4.3.2 Fastener tests.

4.3.2.1 General. The tests described herein are intended to indicate the relative performance of various types of fasteners when used in the fabrication of nailed wood boxes. Since these tests are comparative in nature, the appropriate standard fasteners designated in 3.1.2 must be tested concurrently with the alternate fasteners being considered to replace them. Five test specimens will be required for each variety of fastener to be evaluated. These specimens will be prepared from the same thickness and group of wood as will be employed in fabricating the boxes and the width of the representative cleat sections of the test specimen will be the same as that specified for the container in which the fasteners are planned to be used. No test specimen shall contain split members. Nails and other fastenings shall be driven so that neither the head nor the point will project above the surface of the wood (except for the purpose of clinching where required). Specimens shall be cut and fabricated so that only side grain nailing is utilized. Each of the tests shall be performed on a compression tester equipped with an autographic recorder for producing force-deflection curves. The test fixtures for holding the test specimen, as illustrated in figures 14 and 17, shall be designed so that the applied force is perpendicular to the plane of the test member in contact with the loading block. Also the test fixtures and loading blocks shall be dimensioned to provide clearances sufficient to prevent direct contact of the test

specimen with the platen of the compression tester at any time during test prior to failure. The platen speed shall be 0.4 ± 0.1 inch per minute. Failure will be denoted by the complete separation of one member from another in the specimen and will be recorded in terms of the energy required to produce this separation. The required "energy-to-failure" value for each test specimen will be determined by measuring the area under the force-deflection curve from the point of initial loading to the failure point. The average "energy-to-failure" values obtained with the nails and with the other fasteners shall be calculated and this data used to determine the total number of fasteners required. The total number of fasteners shall be not less than the total number of nails that would be required. When additional fasteners are required, the increase should be limited to the number which can be used without causing splitting of the wood members of the box during assembly.

4.3.2.2 Test of fasteners for nailing cleats to end and battens to sides, top and bottom. The test specimen shall consist of two sections of representative cleat stock, measuring 14 inches in length, each secured with two test fasteners as shown in figure 13 to the opposite edges of a representative container end section measuring 6 by 12 inches. The total of four fasteners used to assemble the specimen will be located as shown in figure 13 and shall be clinched not less than 1/8 inch. The test specimens will be mounted in a test fixture such as illustrated in figure 14. The test fixture rests on the lower platen of the compression tester and the compression load is applied to the wood loading block which transmits the applied force to the specimen member representing the container end section. The loading block dimensions shall be such that it covers the entire area of the specimen member it is in contact with except for a 1/4 inch clearance between the sides of the block and the adjacent members. Testing of the specimen will be performed as described in 4.3.2.1.

4.3.2.3 Tests of fasteners for nailing sides, top, and bottom to ends.

4.3.2.3.1 Lateral resistance test. The test specimen shall consist of two sections measuring 2-1/4 by 10 inches representing the sides or the top and bottom sections of a container, each secured with one test fastener as shown in figure 15 to the opposite edges of a representative container end section measuring 6 by 6 inches. The total of two fasteners used to assemble the specimen will be located as shown in figure 15. The specimen test fixture and the testing procedure shall be as described in 4.3.2.2.

4.3.2.3.2 Direct withdrawal resistance test. The test specimen shall consist of a section measuring 5 by 6 inches representing the side of a container, secured with three test fasteners as shown in figure 16 to a representative container end section measuring 3 by 10 inches. The fasteners used to assemble the specimen will be located as shown in figure 16. The test specimens will be mounted in a test fixture such as illustrated in figure 17. The test fixture rests on the lower platen of the compression tester and the compression load is applied to the wood loading block which transmits the applied force to the member representing the container side section. The loading block dimensions are such that it covers the entire area of the specimen member it is in contact with except for a 1/4 inch clearance between

PPP-B-6210

the side walls of the slot in the wood loading block and the adjacent parallel surfaces of the test specimen. The depth of the slot should be great enough to prevent contact of the loading block with the portion of the test specimen within the slot at any time during testing. Testing of the specimen will be performed as described in 4.3.2.1.

4.3.3 Glued joint strength test. A breakage test involving slow application of stress perpendicular to the glue line shall be performed on individual samples cut from pieces previously built (see 3.3.3.1). Evidence of glue failure is cause for rejection.

4.3.3.1 Preparation and treatment of samples. Specimens of built-up glued pieces shall be selected at random to fairly represent all glued pieces in the entire lot. A sample portion approximately 2 inches along the grain by 4 or more inches across the grain, with glue line located approximately at center with respect to the longer dimension, shall be cut from each built-up piece. Any piece or sample with a split, pitch pocket, or other plane of weakness shall not be included among those selected as representative for testing. All portions shall be completely immersed in water having a temperature of $85 \pm 20^{\circ}\text{F}$ for a minimum of 24 hours preceding testing in accordance with 4.3.3.2.

4.3.3.2 Testing of samples. Each wet sample shall be gripped in a vise with glue line parallel to and approximately 1-1/2 inches above the jaws of the vise, then subjected to a bending force by bearing on the projection end of the sample perpendicular to either face and gradually increasing pressure thereon until failure occurs. The joint shall be considered satisfactory if not less than 50 percent wood failure occurs (50 percent breakage in the wood and 50 percent cleavage in the glue line) as estimated by visual examination of the broken sample. At least 80 percent of all glued samples shall be satisfactory when tested and evaluated by this method. Otherwise, one retest is allowed to determine acceptance or rejection of the lot represented by the samples, or all glued joints in the entire lot shall be reinforced with mechanical fastenings in accordance with 3.3.3.2.

4.3.4 Dryness of preservative. One assembled box shall be placed on either end with top open. A red oil soluble dye mixture consisting of 5 parts by weight of red oil soluble dye to 95 parts of borax (see 6.6), shall be applied along the interior juncture lines of the sides and bottom with the end panel of the box. Observation shall be made for discoloration of the solution (red or deep pink) within 5 minutes from time of application when tested at 50°F or above. Discoloration of the solution shall be cause for rejection. Components of KD boxes shall be tested by placing the sample in a vessel tray or other satisfactory means for containing the solution, applying the solution to the samples, and observing for discoloration as stated above. Discoloration of the solution shall be cause for rejection of the lot.

5. PACKAGING

5.1 Packing. Packing shall be level C.

5.2 Packing, level 1. Boxes are to be shipped, assembled, except for top, or knocked down as specified (see 5.2).

5.2.1 Knocked-down ends cleated (shook form). Each component panel assembly (sides, top, bottom, and ends) shall be separately bundled or crated in quantities that permit easy loading and handling. Packs shall be prepared for shipment to comply with Uniform Freight Classification or National Motor Freight Classification, as applicable.

5.2.2 Assembled, except for top (made-up form). Assembled boxes require no packing. The top panel shall be placed within each box or they shall be separately bundled or crated in quantities that permit easy loading and handling. Packs shall be prepared for shipment to comply with Uniform Freight Classification or National Motor Freight Classification, as applicable.

5.3 Marking.

5.3.1 Civil agencies. In addition to any special markings required by the contract, marking shall be in accordance with the requirements of FED-STD-123.

5.3.2 Military requirements.

5.3.2.1 Knocked-down ends cleated (shook form). Each bundle or crate shall have securely attached thereto a paper or cloth tag, legibly printed, typed or marked in accordance with MIL-STD-129 with the following information:

Quantity
 Component part of box, such as top, bottom, side, or end
 Box size, class, style, and Federal Stock Number (if applicable)
 Name and address of manufacturer
 Contract number
 Shipping address

5.3.2.2 Assembled boxes, except for top (made-up form). When boxes are made up with the top packed therein, 10 percent of the boxes in the lot shall be tagged and marked as specified in 5.3.2.1. If the top is bundled or crated, each bundle or crate shall be tagged and marked as specified in 5.3.2.1.

6. NOTES

6.1 Type of load (see 1.2.3). The construction of a wood box is effected by the type of load. Load types are defined as type 1, easy load; type 2, average load; and type 3 difficult load; as described in ANSI STD MH 15.1.

6210

6.2 Ordering data. Purchasers should select the preferred options permitted herein and include the following information in procurement documents:

- (a) Title, number, and date of this specification.
- (b) Class and style required (see 1.2.1).
- (c) When grade A boxes are required (see 1.2.2).
- (d) Type of load (see 1.2.3).
- (e) When materials other than specified are required (see 3.1).
- (f) When dimensions are other than interior and when other tolerances are unacceptable (see 3.2).
- (g) Weight of contents (see tables I, II, III, and IV).
- (h) When end cleats are required for small style 2, 2-1/2, 4, and 4-1/2 boxes (see tables I, II, III, and IV).
- (i) When diagonals are to be added and location (see 3.3.5.3).
- (j) When 4-way fork entry is required on skids (see 3.3.5.4).
- (k) When beveled skids are required (see 3.3.5.4).
- (l) When skids are to be fabricated from two pieces of lumber (see 3.3.5.4).
- (m) When screws are required (see 3.3.7).
- (n) When top and bottom shall not be nailed to box sides (see 3.3.6.4).
- (o) When identification markings are not required (see 3.5).
- (p) Whether boxes are to be shipped, assembled or knocked down (see 5.2).
- (q) When screws are required to secure ends (see 30.1.1.1).
- (r) When other than specified strapping is required (see 30.2.1, 30.2.1.1 and 30.2.1.2).
- (s) When overdriving of nails and fasteners in cleats are to be limited (see 3.3.6.6 and 6.7).
- (t) Quality classification of lumber required (see 3.1.1).

6.3 Chemically etched nails. The following procedure is suggested for chemically etching bright nails:

(a) Prepare a 10 percent solution (by weight) of commercial monoammonium phosphate in water. Do not use metal container for preparing or storing solution. Keep solution near room temperature (about 68°F).

(b) Immerse nails in solution for about 7 hours, stirring occasionally. Five gallons of solution is sufficient to etch about 100 pounds of nails.

(c) At end of etching period, remove nails and rinse with water.

(d) Air dry nails to prevent rusting.

6.4 Glossary of terms. (Exceptions or additions to requirements specified in MIL-S10-731).

6.4.1 Part. For the purpose of this specification, a part is the cut-to-size component of a shook or box, such as a side, top, bottom, end, cleat, or batten.

6.4.2 Piece. A piece is any width stock. A single solid piece is one which is without joints.

6.4.3 Built-up piece. A built-up piece is two or more single solid pieces joined together in accordance with 3.3.3.1, or 3.3.3.2.

6.4.4 One-piece part. A one-piece part is one composed of one single solid piece or one built-up piece which forms one solid component of a shook or box.

6.4.5 Cleat. A cleat is a single solid piece used to reinforce the ends of a shook or box.

6.4.6 Batten. A batten is a single solid piece used to reinforce the sides, top and bottom of a shook or box and may be placed inside or outside of the box as feasible for a given load or contents.

6.4.7 Knot cluster. A knot cluster consists of two or more knots grouped together as a unit with the wood fibers deflected around the entire unit. A knot cluster is properly measured as a unit rather than as individual knots.

6.4.8 Group of knots. A group of knots consists of two or more knots in close proximity within a piece or part, with the wood fibers deflected around each individual knot. The knots within the group are properly measured individually.

6.4.9 Loose knot. A knot that extends through the thickness of the piece and is partially or completely encased (separated from the surrounding wood by bark or film of pitch) is defined as a loose knot unless 1/4 of the circumference is intergrown with the surrounding wood on at least one side of the piece.

6.5 Style 7 box. The style 7 box stipulated herein is an internally reinforced box consisting of a skidded base with a separate hood to be furnished only when specified. Style 7 boxes may be specified for contents in the 100-to 1000-pound range to readily permit attachment of item(s) to the skid base, facilitate protective shrouding of the load, permit fork-lift handling, provide durability and protection by maximum reinforcement, and permit reusability. The bottom is assembled to the skids to permit mounting of the item. The side, end, and top panels are prefabricated, then assembled as a hood as shown in figures 11, 11A, and 11b. The hood assembly is placed over the item mounted to the bottom and nailing and strapping is accomplished.

PPP-b-621D

6.6 "Penetration", prepared by the Keystone Aniline Company, has been found to be a satisfactory soluble dye mixture for this purpose (see 4.3.4).

6.7 Overdriving of fasteners in cleats. Cleats of boxes are sometimes used for marking purposes such as boxes packed with ammunition items. Limiting the number of overdriven fasteners in cleats per box as specified in 3.3.6.6 preserves the cleats even surface and this aids in the application and legibility of the marking.

6.8 Definitive specification part number. (see attached).

6.9 Deletion. Style 3 has been deleted. It is no longer required.

APPENDIX

10. SCOPE

10.1 This appendix covers requirements for assembly, closure, and steel strapping of packed boxes.

20. APPLICABLE DOCUMENTS

20.1 The following documents, of the issues in effect on date of invitation for bids or request for proposal, form a part of this appendix to the extent specified herein:

Federal Specifications;

QQ-S-781 - Strapping, Steel, and Seals

Federal Standard:

FED-STD-101 - Preservation, Packaging, and Packing Materials
Test Procedures

(Activities outside the Federal Government may obtain copies of Federal specifications, standards, and commercial item descriptions as outlined under General Information in the Index of Federal Specifications, Standards and Commercial Item Descriptions. The Index, which includes cumulative bimonthly supplements as issued, is for sale on a subscription basis by the Superintendent of Documents, US Government Printing Office, Washington, DC 20402.

(Single copies of this specification, other Federal specifications, standards, and commercial item descriptions required by activities outside the Federal Government for bidding purposes are available without charge from General Services Administration Business Service Centers in Boston; New York; Washington, DC, Philadelphia; Atlanta; Chicago; Kansas City, MO; Fort Worth, Houston; Denver; San Francisco; Los Angeles; and Seattle WA.

(Federal Government activities may obtain copies of Federal specifications, standards, and commercial item descriptions, and the Index of Federal Specifications, Standards and Commercial Item Descriptions from established distribution points in their agencies.)

30. REQUIREMENTS

30.1 Assembly. All boxes, except style 7 (see 30.1.1), shall be assembled as specified in section 3. Nailing and closure of boxes shall be in compliance with section 3.

PPP-B-621D

30.1.1 Style 7 boxes.

30.1.1.1 Box ends. The sheathing on the box ends shall be applied vertically as shown on figure 11b. The sheathing shall be nailed to the interior frame members and the side of the skid. When specified (see 6.2), the end sheathing shall be attached to the interior frame and the skid with screws.

30.1.1.2 The sides and top shall be flush with the outside surface of each panel when assembled.

30.2 Strapping.

30.2.1 Strapping required herein shall be performed when the box is packed for shipment. Strapping materials shall be furnished by the box packer. Strapping shall conform to class 1, type I or IV, finish A or B; or class 2, type V or VI, finish A or B of QQ-S-781 (see 6.2). The strength of the seal joint shall be not less than 75 percent of the rated tensile strength of the flat or round wire strapping, as applicable, (see QQ-S-781) when tested as specified in 40.2. All strapping shall encircle the box.

30.2.1.1 Class 1 boxes. Unless otherwise specified (see 6.2), style 1 and 6 boxes, regardless of weight, and styles 2, 2-1/2, 4, 4-1/2, 5, and 7 boxes, with weight of contents exceeding 100 pounds, shall be strapped as specified herein. When specified, style 2, 2-1/2, 4, 4-1/2 and 5 boxes, with weight of contents less than 100 pounds, shall be strapped in accordance with the provisions of this appendix.

30.2.1.2 Class 2 boxes. Unless otherwise specified (see 6.2), all boxes shall be strapped in accordance with provisions of this appendix.

30.2.2 Size. The size of round wire strapping shall be as specified in table XIX, and the size of flat strapping shall be as specified in table XX.

30.2.3 Tightness. All straps shall be applied perpendicular to the edges of the box over which they pass and shall be drawn tight so as to sink into the wood at the edges. Straps shall be applied just prior to shipment where practicable.

30.2.4 Distance of straps from box ends. If two or more straps are used, the distance between end straps and the ends of the box shall be approximately 1/6 the length of the box but shall not exceed a distance of 9 inches.

30.2.5 Number of straps to be used for style 2, 2-1/2, 4, 4-1/2, 5, and shallow boxes. Two or more straps shall be applied girthwise, except that only one strap shall be applied girthwise when the weight is less than 35 pounds and the length does not exceed 12 inches. The single girthwise strap maybe 16 gage, round wire, or 3/8 by 0.010 inch flat strapping. When the outside length of the box exceeds 36 inches, three or more straps shall be applied girthwise so that the distance between straps is not more than 24 inches.

30.2.6 Number of straps to be used for reinforced style 2, 2-1/2, 4, 4-1/2, and 5 boxes. Two or more straps shall be applied girthwise so that the distance between straps is not more than 24 inches. Straps are applied over batten centerlines when battens are used internally.

TABLE XIX. Minimum gage of round wire

Net weight of contents Pounds	Gage of wire when different number of wires are used			
	Two straps		Three (or more) straps	
	Class B Inch	Class A Inch	Class B Inch	Class A Inch
Not exceeding 70	0.0720 (15 gage)	0.0625 (16 gage)	0.0720 (15 gage)	0.0625 (16 gage)
125	.0800 (14 gage)	.0720 (15 gage)	.0800 (14 gage)	.0720 (15 gage)
175	.0915 (13 gage)	.0800 (14 gage)	.0915 (13 gage)	.0800 (14 gage)
250	.0915 (13 gage)	.0915 (13 gage)	.0915 (13 gage)	.0915 (13 gage)
400	.1055 (12 gage)	.0990 (12-1/2 gage)	.0915 (13 gage)	.0915 (13 gage)
1000			.1055 (12 gage)	.0990 (12-1/2 gage)

TABLE XX. Minimum sizes of flat metal straps

Net weight of contents Pounds	Dimensions of flat metal straps when different numbers of straps are used		
	Two straps		Three or more straps
	Inch		Inch
Not exceeding 70	3/8 by 0.015	3/8 by 0.015	3/8 by 0.015
125	3/8 by .020	3/8 by .020	3/8 by .020
175	1/2 by .020	1/2 by .020	1/2 by .020
250	5/8 by .020	5/8 by .020	5/8 by .020
400	3/4 by .020	3/4 by .020	3/4 by .020
1000			3/4 by .020

202 2 1 12

PPP-8-621D

30.2.6.1 When straps and exterior diagonals intersect, the diagonals shall be notched slightly, before attachment, to permit threading of strapping under each diagonal after closing the box (see 3.3.5.3).

30.2.6.2 When boxes are equipped with skids or external battens, or both, strapping shall be applied adjacent to each skid.

30.2.7 Number of straps to be used for style 1 and 6. Style 1 and 6 shall have one strap applied lengthwise around the top, bottom, and ends, and then, two additional straps shall be applied girthwise.

30.2.8 Number and locations of straps to be used for style 7 boxes. When strapping is required (see 30.2), one strap shall be applied parallel to and immediately adjoining the inner edge of each skid, as shown in figures 11, 11a, and 11b. Three or more straps, equally spaced, are required when spacing between straps exceeds 24 inches.

30.3 Marking.

30.3.1 Civil agencies. In addition to any special marking required by the contract or order, shipping containers shall be marked in accordance with FED-STD-123.

30.3.2 Military requirements. In addition to any special marking required by the contract or order, shipping containers shall be marked in accordance with MIL-STD-129.

40. INSPECTION PROCEDURES

40.1 Inspection. The boxes shall be inspected to determine compliance with requirements of this appendix. Sampling shall be in accordance with MIL-STD-105.

40.1.1 Inspection for closure, strapping, and marking. Classification of defects for closure, steel strapping, and marking shall be as specified in table XXI. The lot size for this examination shall be expressed in boxes. The sample unit shall be one assembled and closed box. The inspection level shall be S-3 and the AQL shall be 4.0 major and 10.0 for total (major and minor combined) defects per hundred units.

30.2.1. Closure, strapping, and marking defects

Examine	Defect	Category	
		Major	Minor
Strapping (when required)	Not placed as specified	101	
	Torn or cut, or missing	102	
	Loose strap		201
	Not encircling the box	103	
Condition of box	Broken or damaged components	104	
Marking	Omitted, incomplete, incorrect, illegible, of improper size, location, sequence or method of application	105	

40.2 Testing of seal joint. Three seal joints from the boxes in the end item inspection lot shall be tested in accordance with Method 2044 of FED-STD-101. Failure to meet the requirements of 30.2.1 shall be cause for rejection of the lot.

8-621D

6.8 Definitive Specification Part Number. The specification part number is a definitive part number which will be formulated to identify each item. The part number will be formulated by selecting from the requirement options available in this specification as follows:

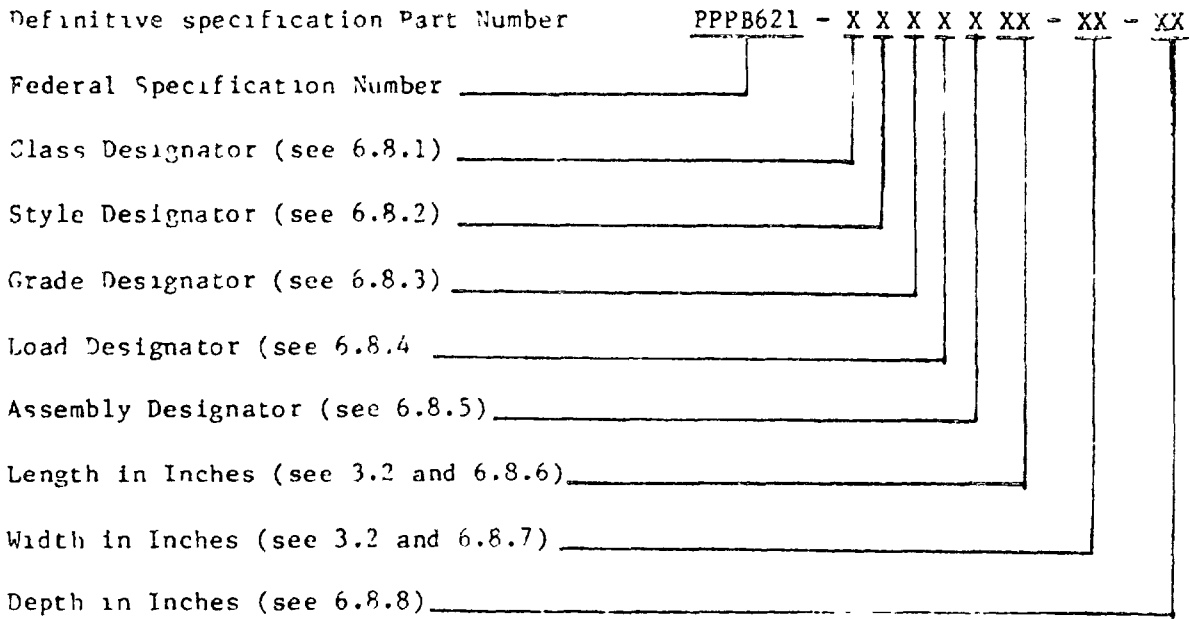

6.8.1 Class Designator. A one position field used to designate the required class of box (see table XXII).

TABLE XXII

Class	
Designator	Remarks
1	Domestic (see 1.2.1)
2	Overseas (see 1.2.1)

6.8.2 Style Designator. A one position field used to designate the required style of box (see table XXIII.).

TABLE XXIII

Style Designator	Style	Remarks
A	Style 1	Available in Domestic Only (see figure 1)
B	Style 2	Available in Both Classes (see figures 2 & 13)
C	Style 2-1/2	Available in Both Classes (see figure 3)
D	Style 4	Available in Both Classes (See figure 4)
E	Style 4-1/2	Available in Both Classes (see figure 5)
F	Style 5	Available in Both Classes (see figure 6)
G	Style 6	Available in Domestic Only (see figure 7)
H	Style 7	Available in Both Classes (see figures 11, 11a, & 11B)

PPP-B-621D

6.8.3 Grade Designator. A one position field used to designate the required grade or box (see table XXIV).

TABLE XXIV

Grade Designator	Remarks
A	With preservative treatment
B	Without preservative TRTMT

6.8.4 Load Designator. A one position field used to designate shipment loads (see table XXV).

TABLE XXV

Load Designator	Remarks
1	Easy (see 6.1)
2	Average (see 6.1)
3	Difficult (see 6.1)

6.8.5 Assembly Designator. A one position field used to designate whether the boxes are to be shipped assembled or knocked down (see table XXVI).

TABLE XXVI

Assembly Designator	Remarks
A	Assembled (see 6.2)
K	Knocked-down (see 5.2)

6.8.6 Length. Designate the required length of the box in inches (see 3.2).

6.8.7 Width. Designate the required width of the box in inches (see 3.2).

6.8.8 Depth. Designate the required depth of the box in inches (see 3.2).

SAMPLE PART NUMBER

Federal Specification No.	_____	PPPB621	-	1	C	B	2	A	48	-	24	-	14
Domestic Class _____	_____	_____	_____	_____	_____	_____	_____	_____	_____	_____	_____	_____	_____
Style 2-1/2 _____	_____	_____	_____	_____	_____	_____	_____	_____	_____	_____	_____	_____	_____
Without Preservative TRTMT _____	_____	_____	_____	_____	_____	_____	_____	_____	_____	_____	_____	_____	_____
Average Load _____	_____	_____	_____	_____	_____	_____	_____	_____	_____	_____	_____	_____	_____
Assembled _____	_____	_____	_____	_____	_____	_____	_____	_____	_____	_____	_____	_____	_____
Length 48" _____	_____	_____	_____	_____	_____	_____	_____	_____	_____	_____	_____	_____	_____
Width 24" _____	_____	_____	_____	_____	_____	_____	_____	_____	_____	_____	_____	_____	_____
Depth 14" _____	_____	_____	_____	_____	_____	_____	_____	_____	_____	_____	_____	_____	_____

Box, in accordance with PPP-B-621, Class 1 for Domestic Shipping, Style 2-1/2, Without Preservative Treatment, Average load, Assembled, 48 inches long, 24 inches wide, and 14 inches deep, measured from inside dimensions.

10-6710

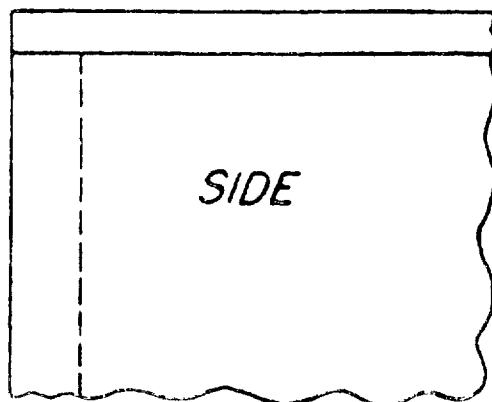
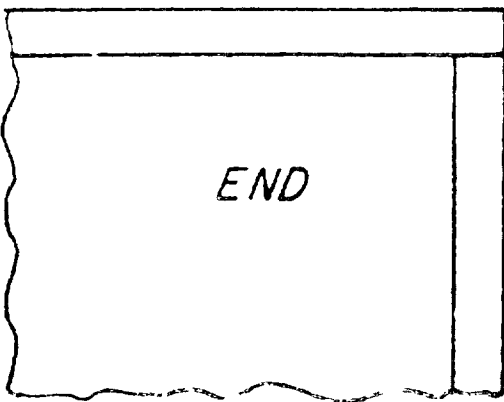
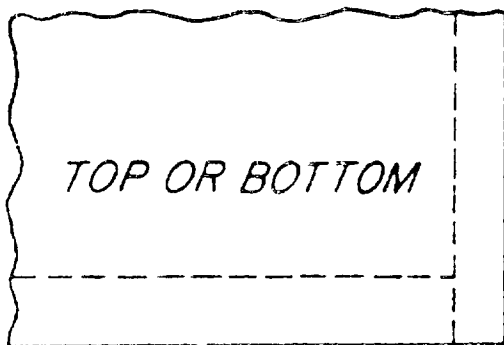
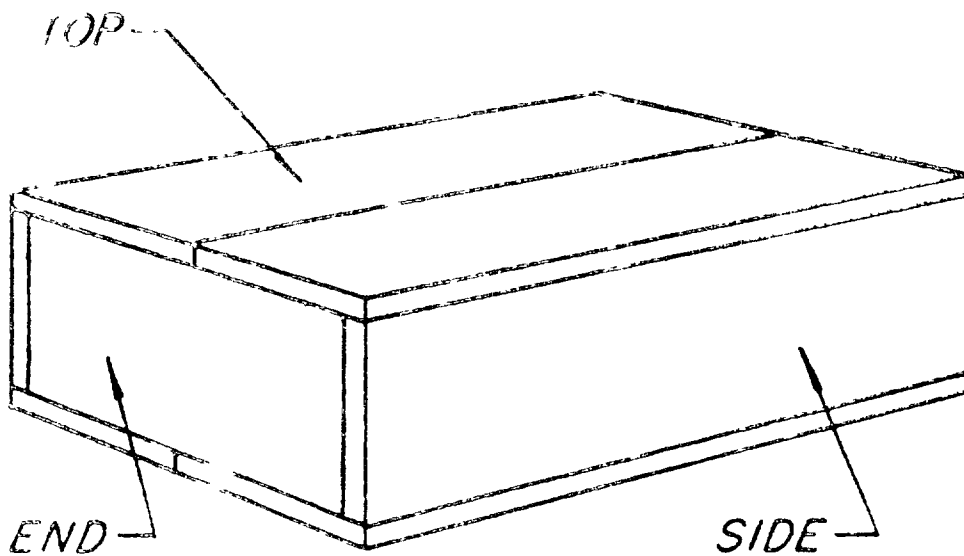

FIGURE 1 STYLE 1 BOX (UNCLEATED ENDS)

215-8-8710

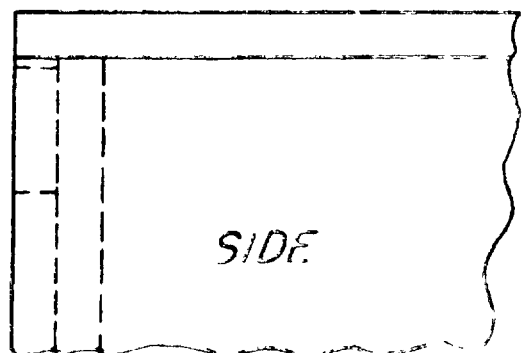
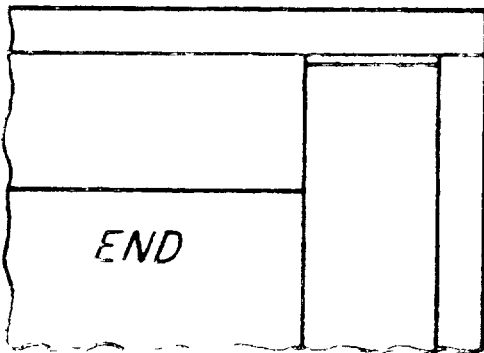
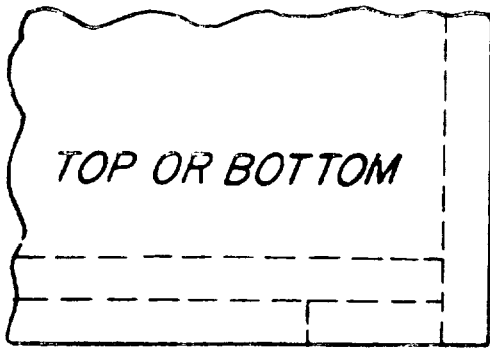
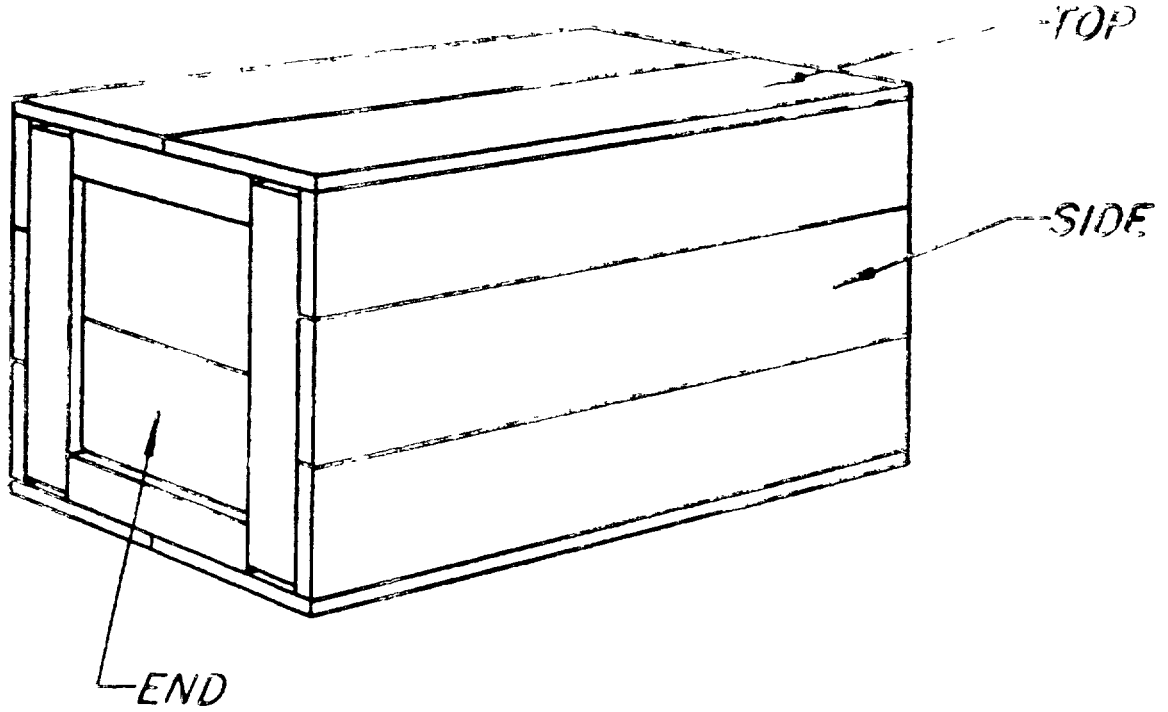

FIGURE 2. STYLE 2 BOX (FULL CREATED ENDS, BUTT JOINERS)

222-3 6710

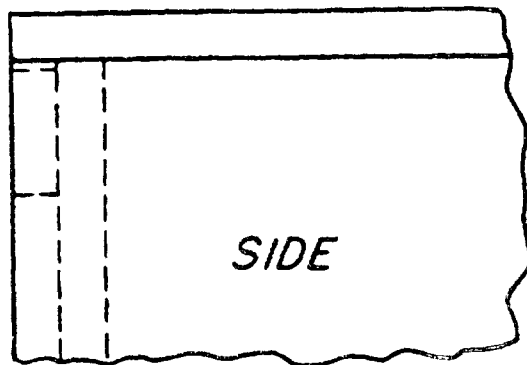
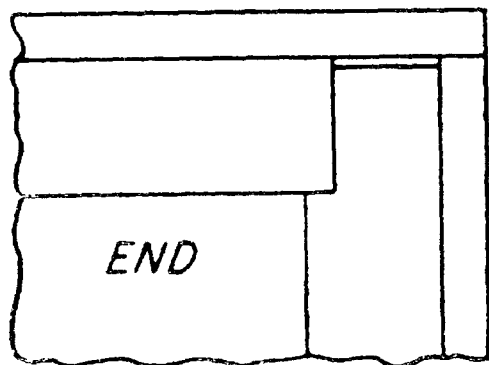
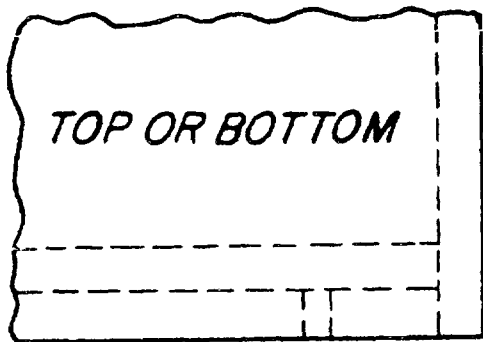
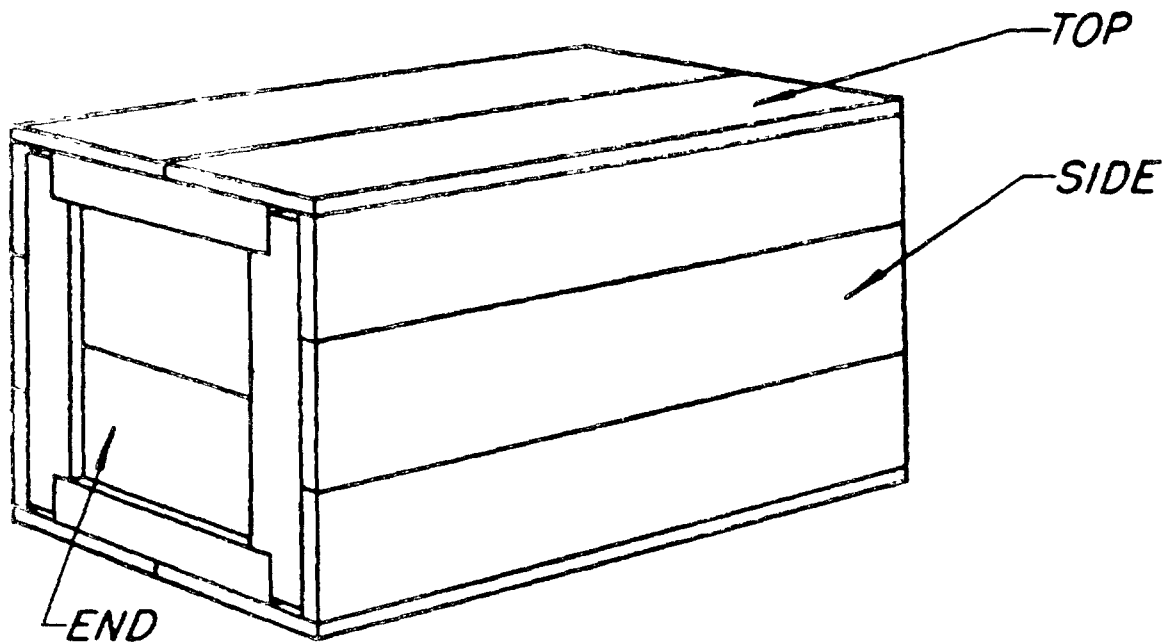

FIGURE 3. STYLE 2 $\frac{1}{2}$ BOX (FULL CLEATED ENDS; NOTCHED CORNERS)

PPP-0-521D

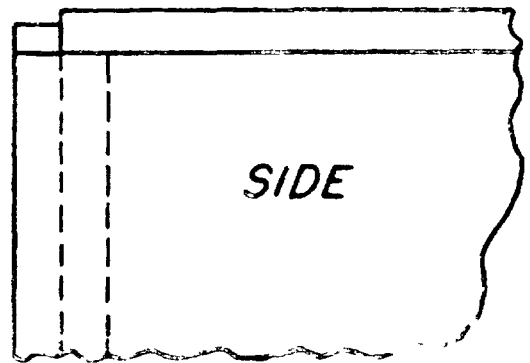
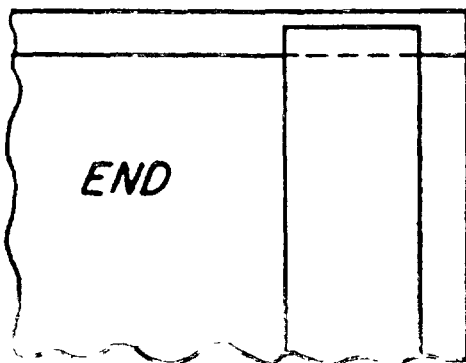
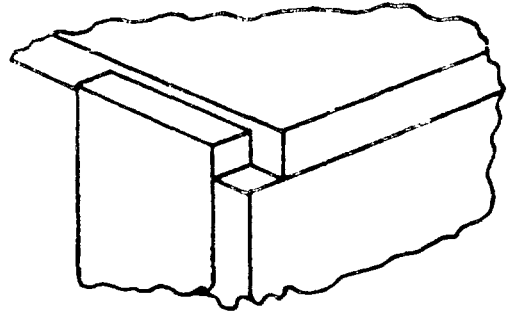
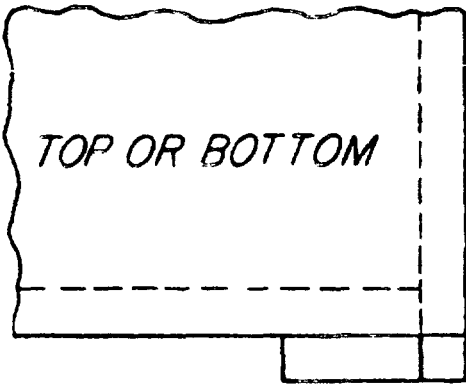
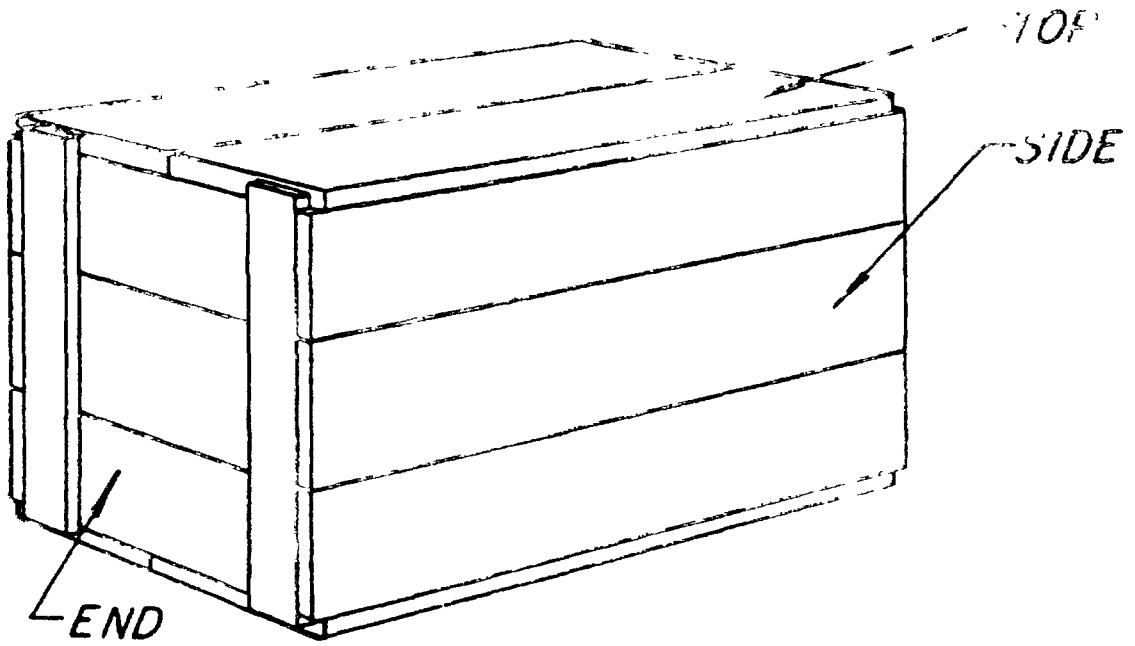
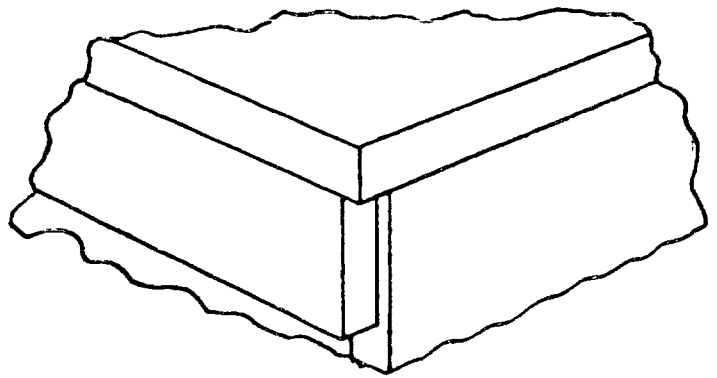
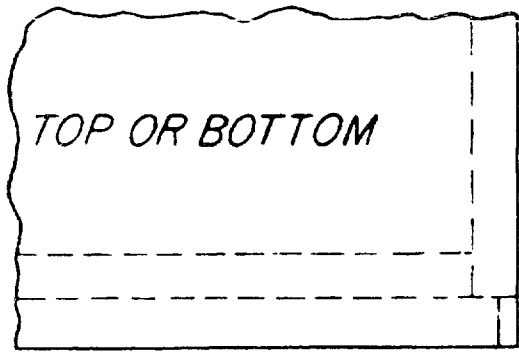
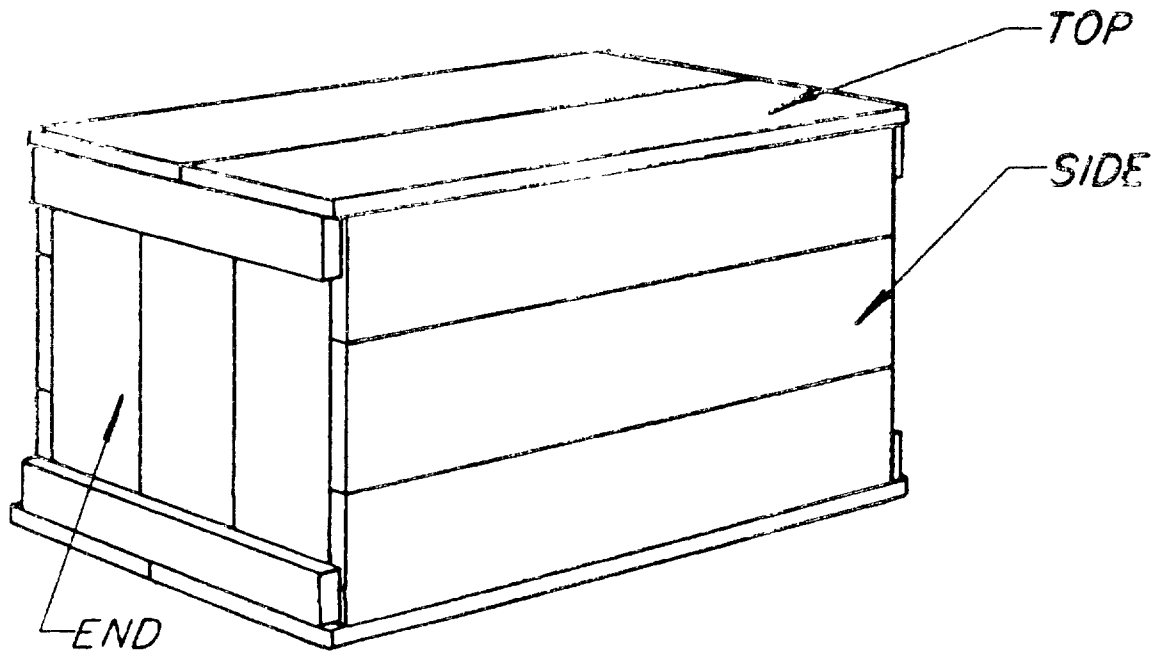

FIGURE 4. STYLE 4 BOX (TWO EXTERIOR END CLEATS)

0229-08-6210



CORNER DETAIL

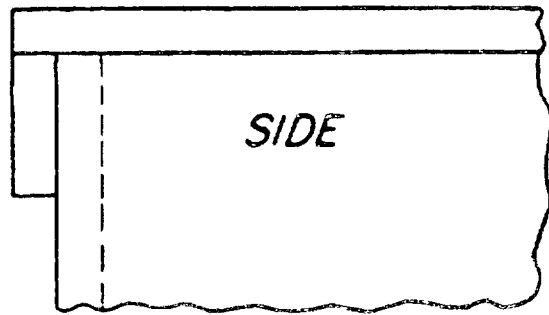
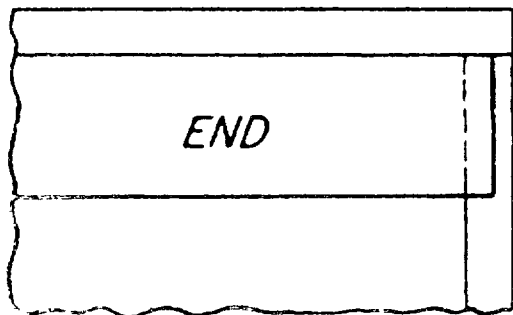

FIGURE 5. STYLE 4 $\frac{1}{2}$ BOX (TWO EXTERIOR END CLEATS)

PPP-3-6/11

ALTERNATE FORMS OF
GLEAIS

SIDE

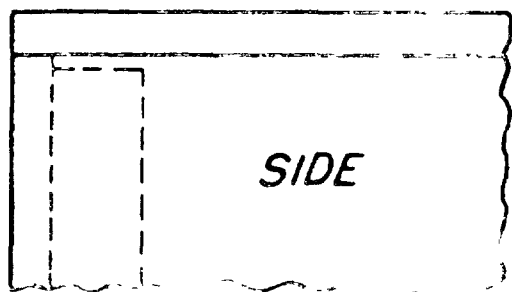
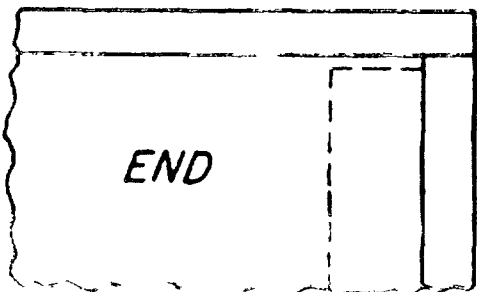
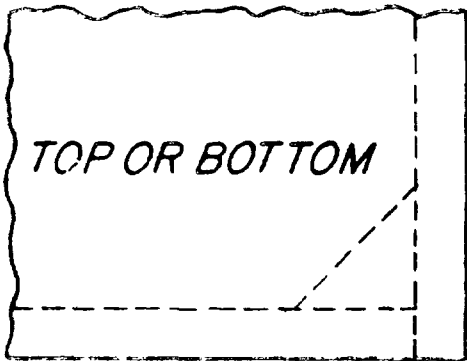
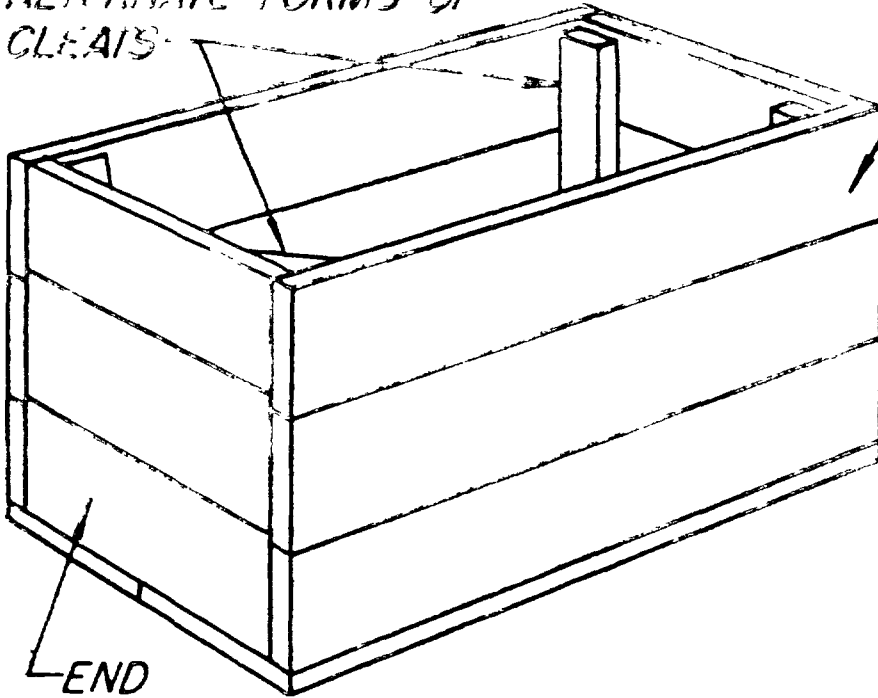

FIGURE 3-51/E-5 BOX (TWO INTERNAL END DIVIDERS)

PPP-3-621D

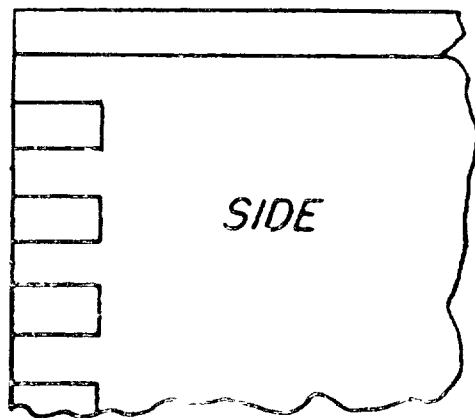
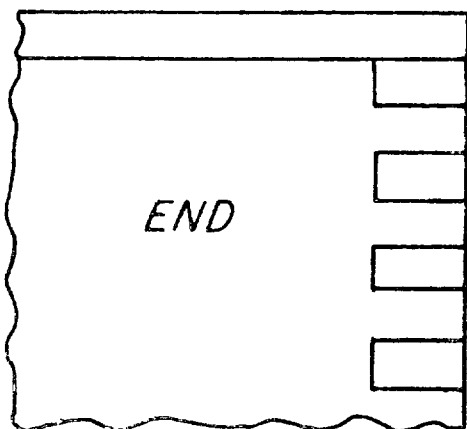
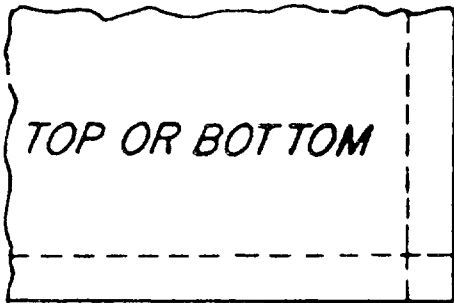
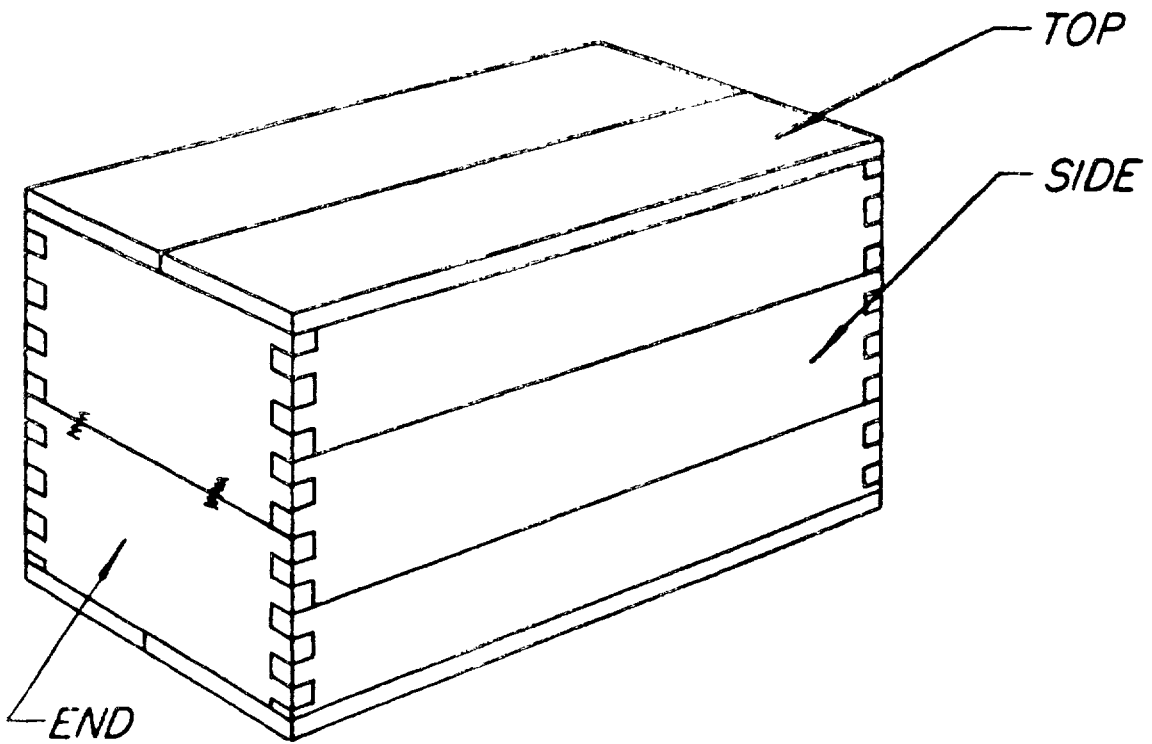
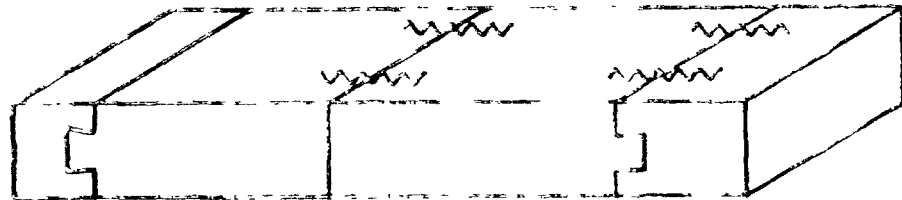

FIGURE 7. STYLE 6 BOX (LOCK-CORNER)



Linderman

Butt

Tongue and Groove

FIGURE 8. TYPES OF BOX JOINTS

طریقہ و عملہ

SPIKE KNOTS

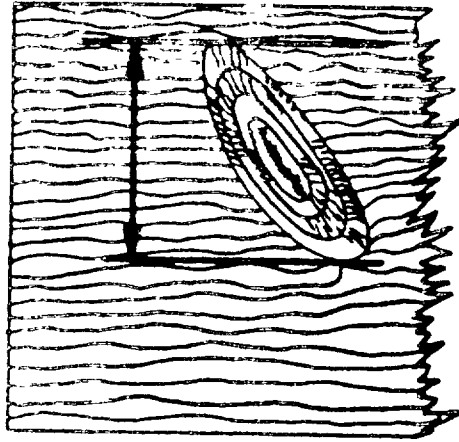

ROUND KNOTS

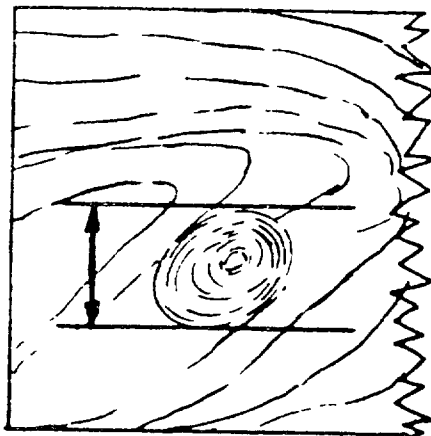

FIGURE 9, METHOD OF MEASURING KNOTS

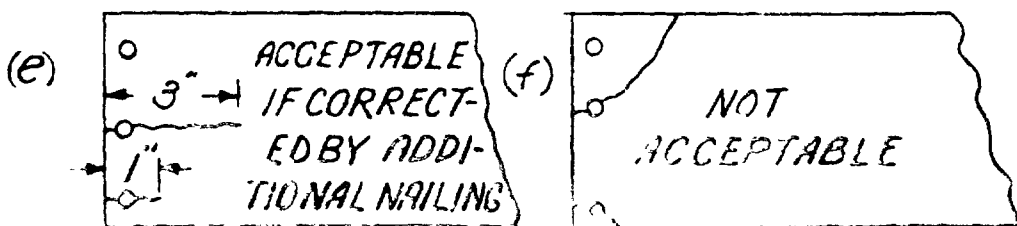
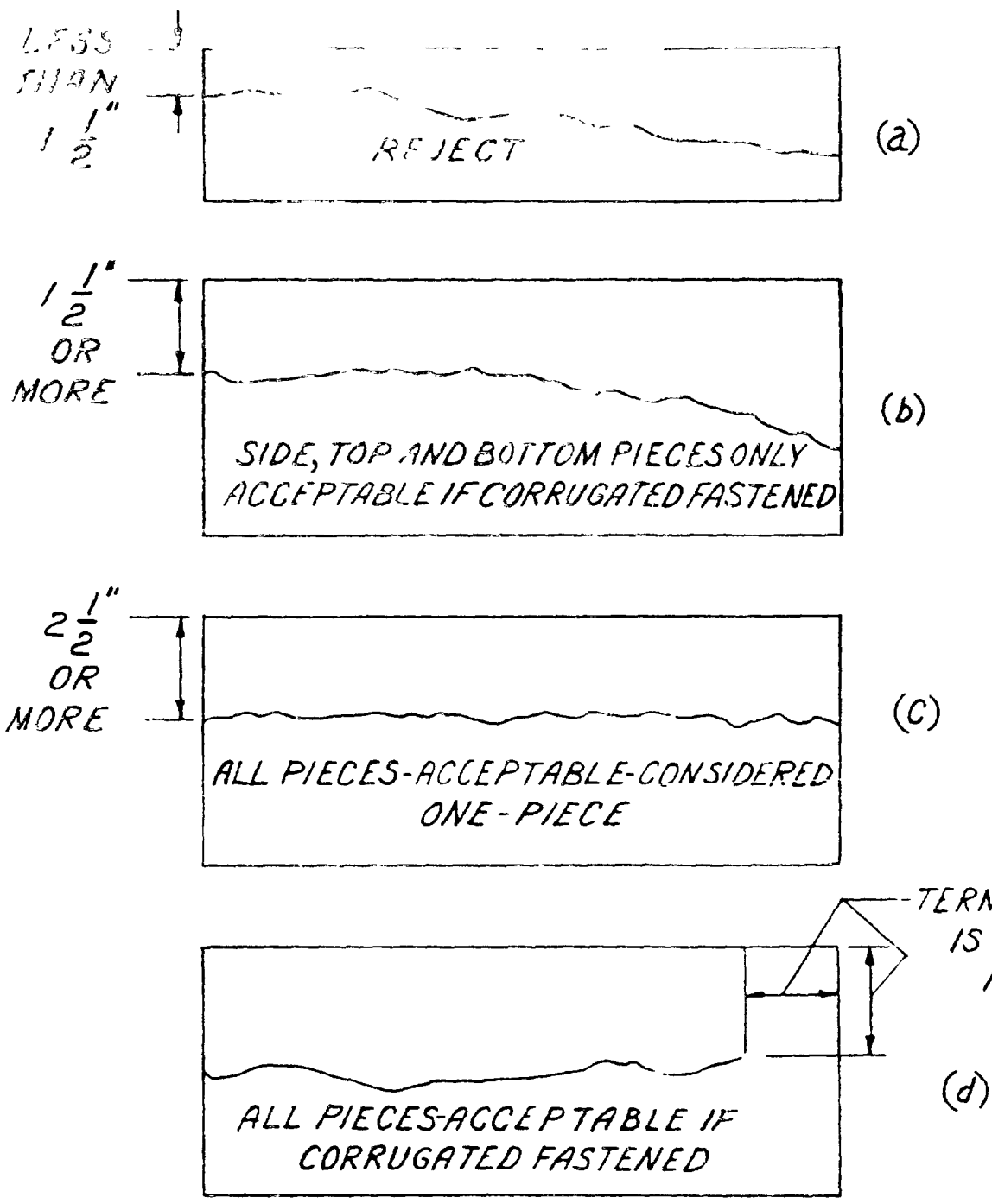
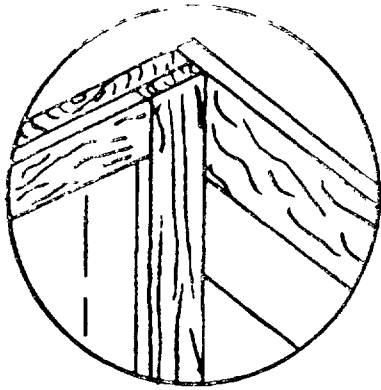
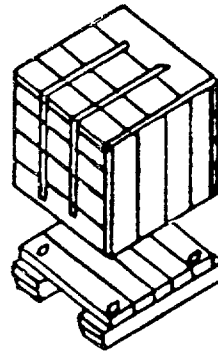

FIGURE 10. EXAMPLES OF SPLITS

222-8-8210



CORNER DETAIL



METHOD OF ASSEMBLING CONTAINER

BOTTOM CLEAT ON END PANEL WILL REST ON MBRS OF BASE

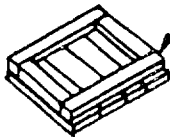

END

THIS DIMENSION TO ALLOW FOR SIDE SHEATHING

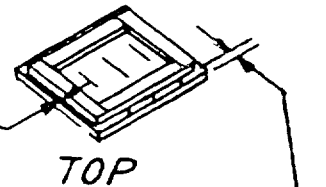

TOP

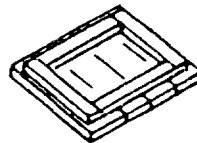

SIDE*

THIS DIMENSION TO ALLOW FOR THICKNESS OF END CLEAT & SHEATHING

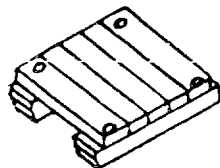

BASE

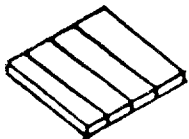

SIDE *

END SHEATHING TO EXTEND TO WITHIN 1/8 OF BOTTOM OF SKIDS

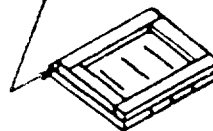

END

COMPLETE BREAKDOWN OF CONTAINER SHOWING COMPONENTS

* ADD FRAMING MEMBERS WHEN: CONTENTS EXCEED 250 LBS OR WHEN SIDE LENGTH IS GREATER THAN END LENGTH

FIGURE 11. EXAMPLE OF STYLE 7 BOX WITH SEPARATE HOOD (MINIMUM REQUIREMENTS)

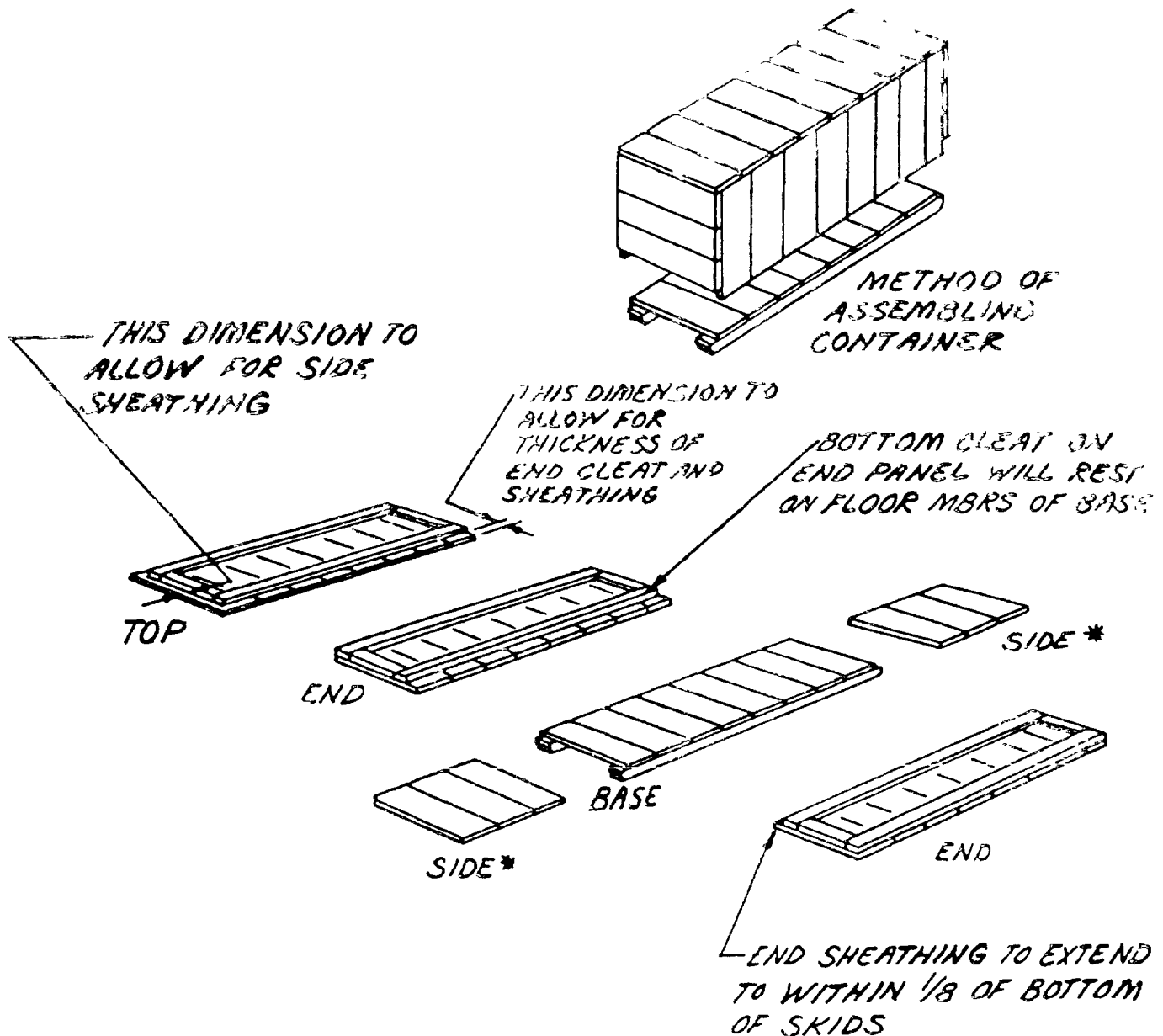

*ADD FRAMING MEMBERS WHEN: CONTENTS EXCEED 250 LBS OR WHEN SIDE LENGTH IS GREATER THAN END LENGTH.

FIGURE 11 & EXAMPLE OF STYLE 7 BOX WITH SEPARATE HOOD (MINIMUM REQUIREMENTS)

6210

CONTENTS LESS THAN 250 LBS
BUT SIDE LENGTH GREATER
THAN END LENGTH

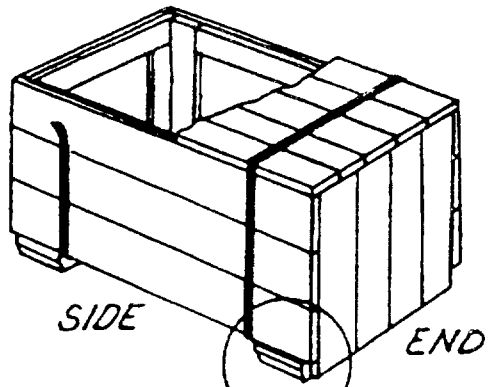
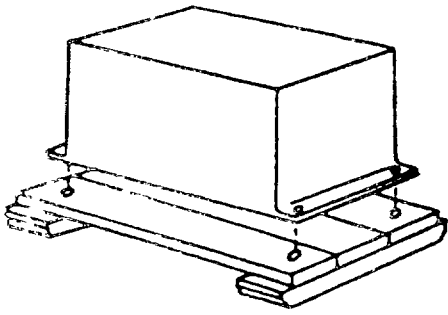

SIDE

END

FULLY
ASSEMBLED BOX

CROSS SECTION
"1"

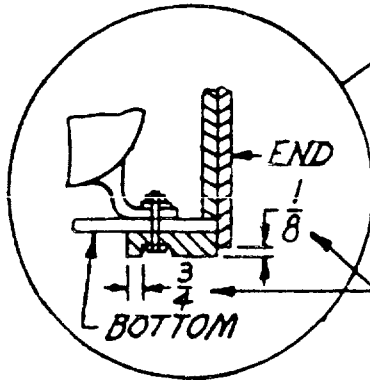

BOLTED MOUNTING
DETAIL

AT LEAST

BOTTOM

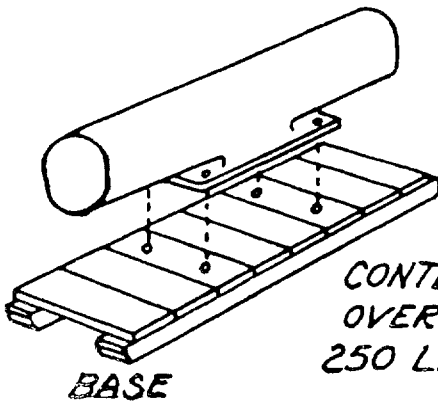

BASE

CONTENTS
OVER
250 LBS

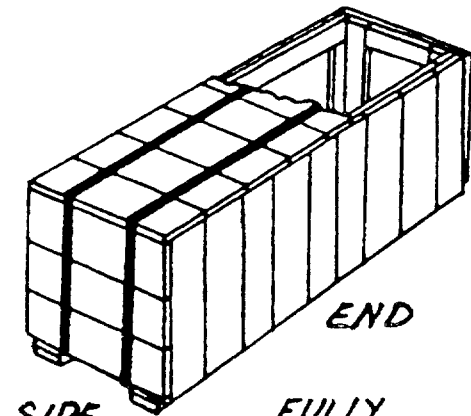

SIDE

END

FULLY
ASSEMBLED BOX

FIGURE 116 STYLE 7 BOX
(SKIDDED BASE & SEPARATE REINFORCED HOOD)

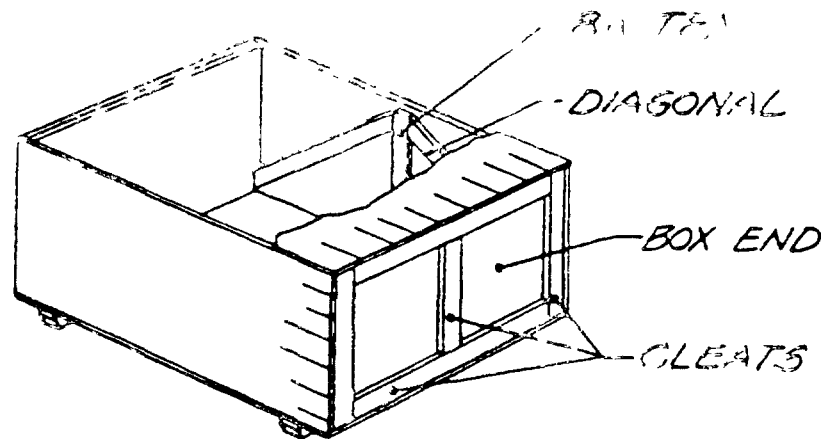

NOTE:

1. FOR REQUIREMENTS FOR BATTENS, DIAGONALS AND SKIDS SEE TABLE VI, 3.3.5.2, 3.3.5.3 AND 3.3.5.4.
2. TOP INTERIOR BATTENS (NOT SHOWN) EXTERIOR BATTENS AND SKIDS BEAR ON ENDS OF SIDE BATTENS
3. THE OUTER END OF EACH INTERIOR SIDE DIAGONAL BEARS ON THE ADJACENT BOX END; OR ON AN END DIAGONAL, WHEN PRESENT.

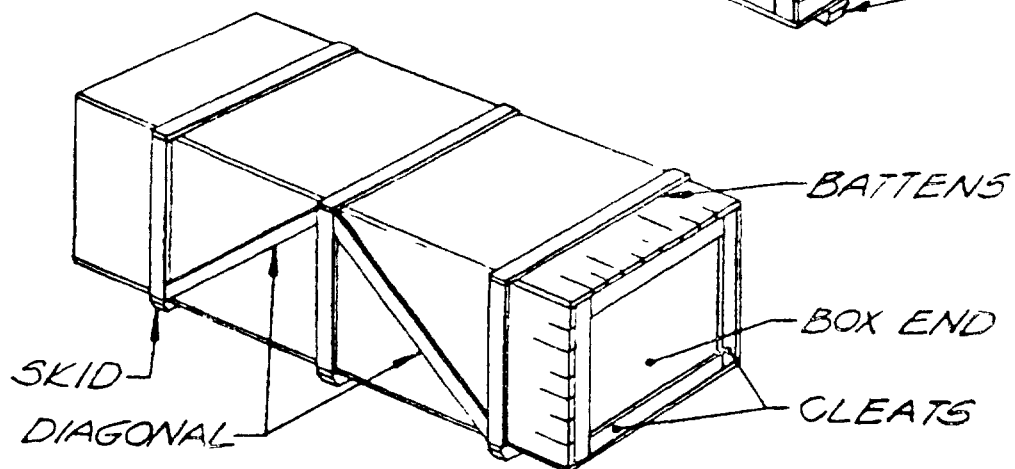
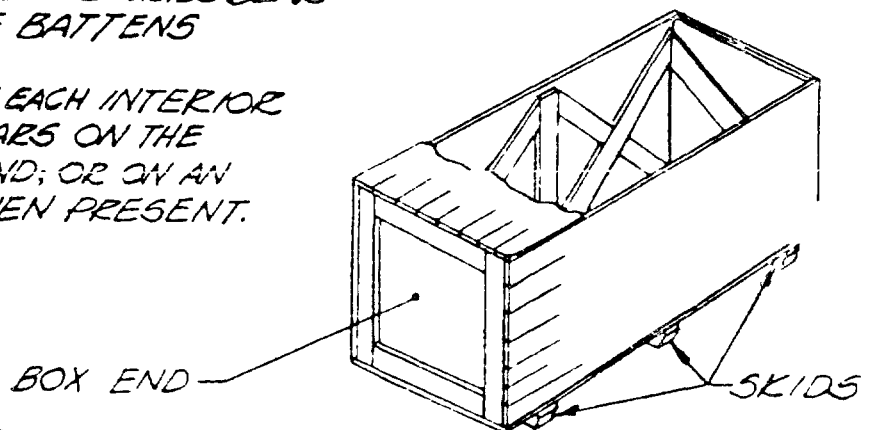
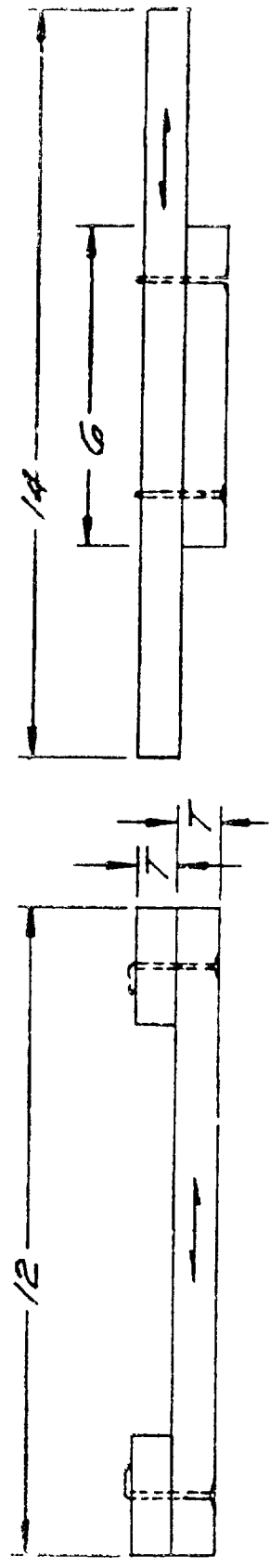
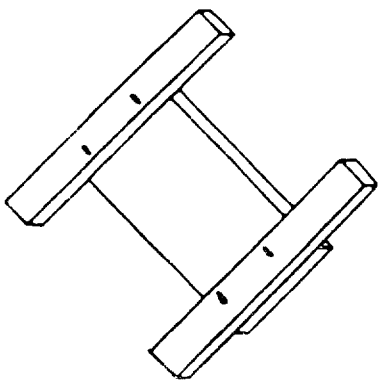

FIGURE 12. EXAMPLES OF REINFORCED STYLE 2 BOXES

172 7 8210

T. CLEAT THICKNESS
→ DIRECTION OF GRAIN



FRONT VIEW SIDE VIEW

FIG 13. TEST SPECIMEN FOR DIRECT WITHDRAWAL RESISTANCE TEST (PARAGRAPH 4.3.2.2)

(((

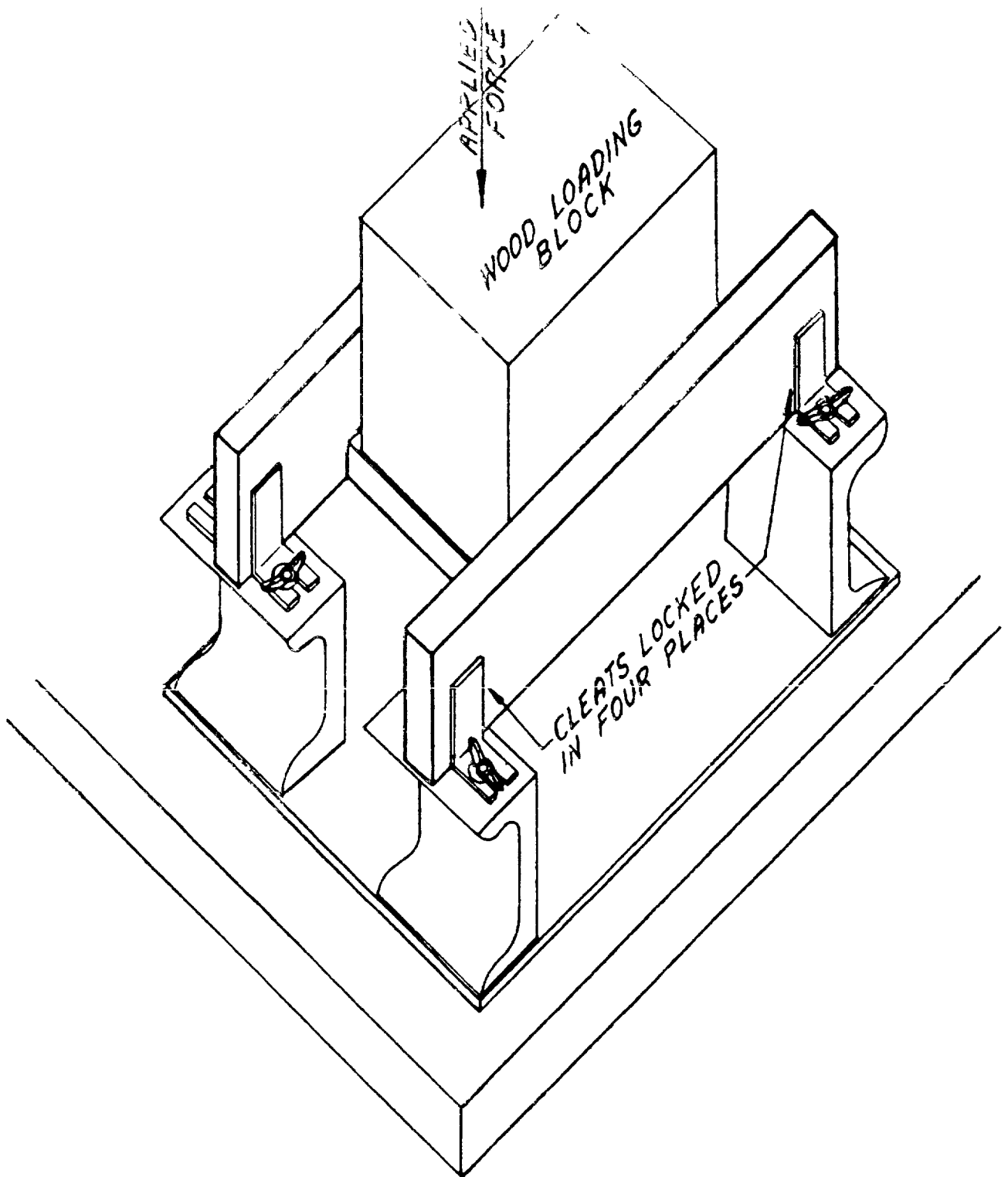

FIGURE 14. TEST FIXTURE FOR DIRECT WITHDRAWAL RESISTANCE TEST (PARAGRAPH 4.3.2.2 AND LATERAL WITHDRAWAL RESISTANCE TEST PARAGRAPH 4.3.2.3.2)

002 1-6-21

T- CLINCH THICKNESS
→ DIRECTION OF GRAIN

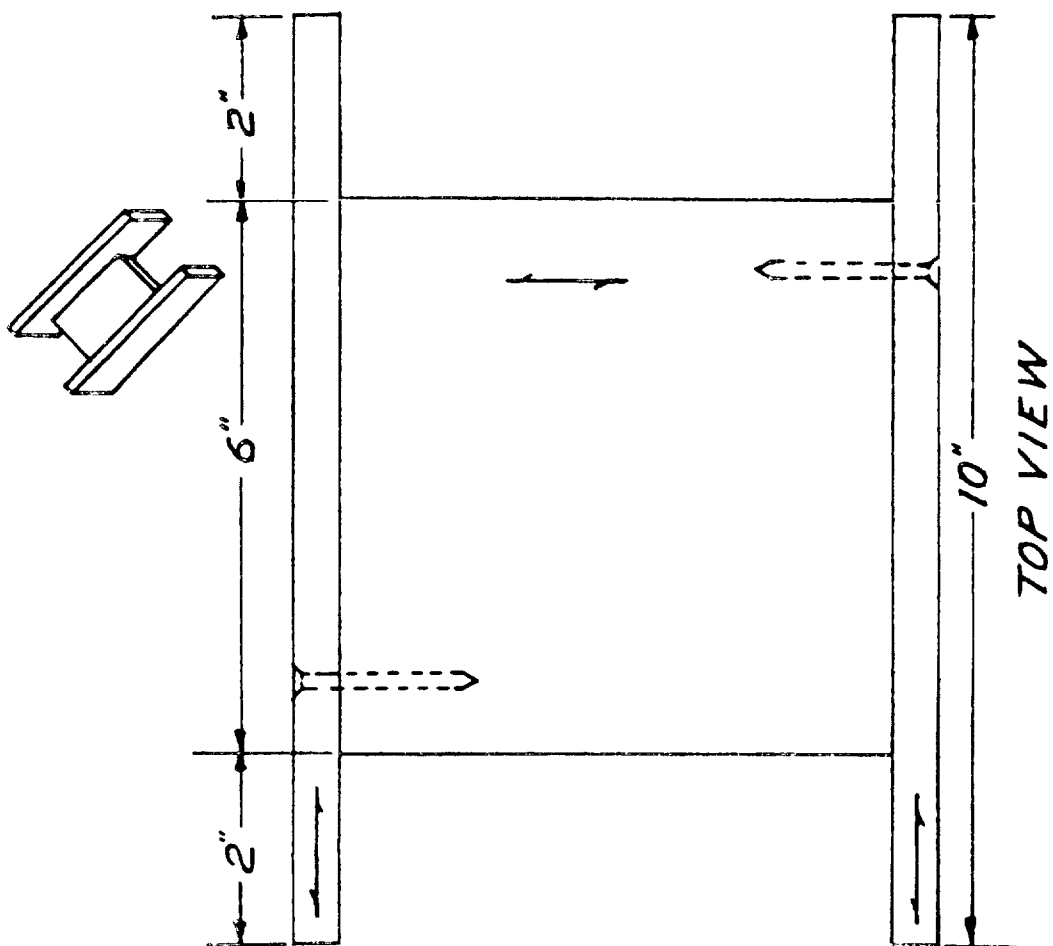
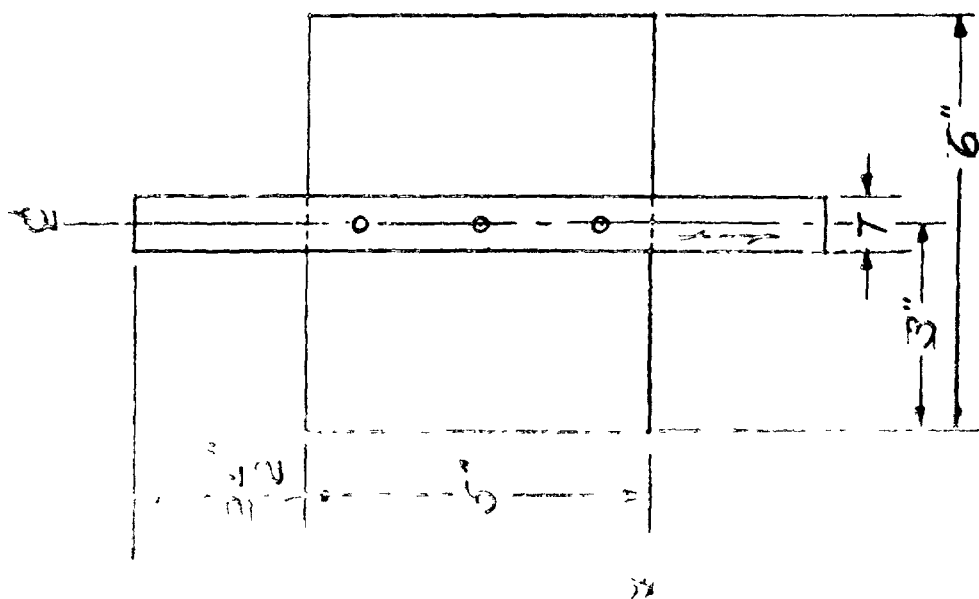
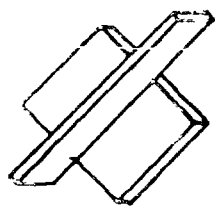
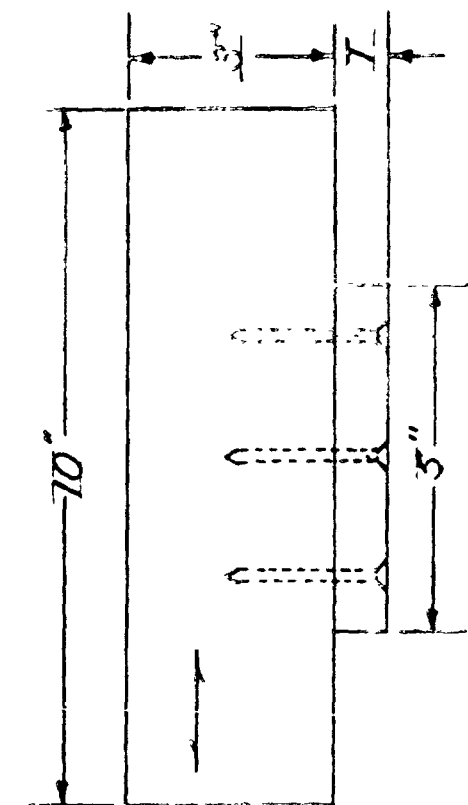

FIGURE 15. TEST SPECIMEN FOR LATERAL RESISTANCE TEST
(PARAGRAPH 4.3.2.3.1)

T CLEAT THICKNESS
→ DIRECTION OF GRAIN



TOP VIEW



SIDE VIEW

FIGURE 16. TEST SPECIMEN FOR DIRECT WITHDRAWAL RESISTANCE TEST
(PARAGRAPH 4.3.2.3.2)

222-0-6170

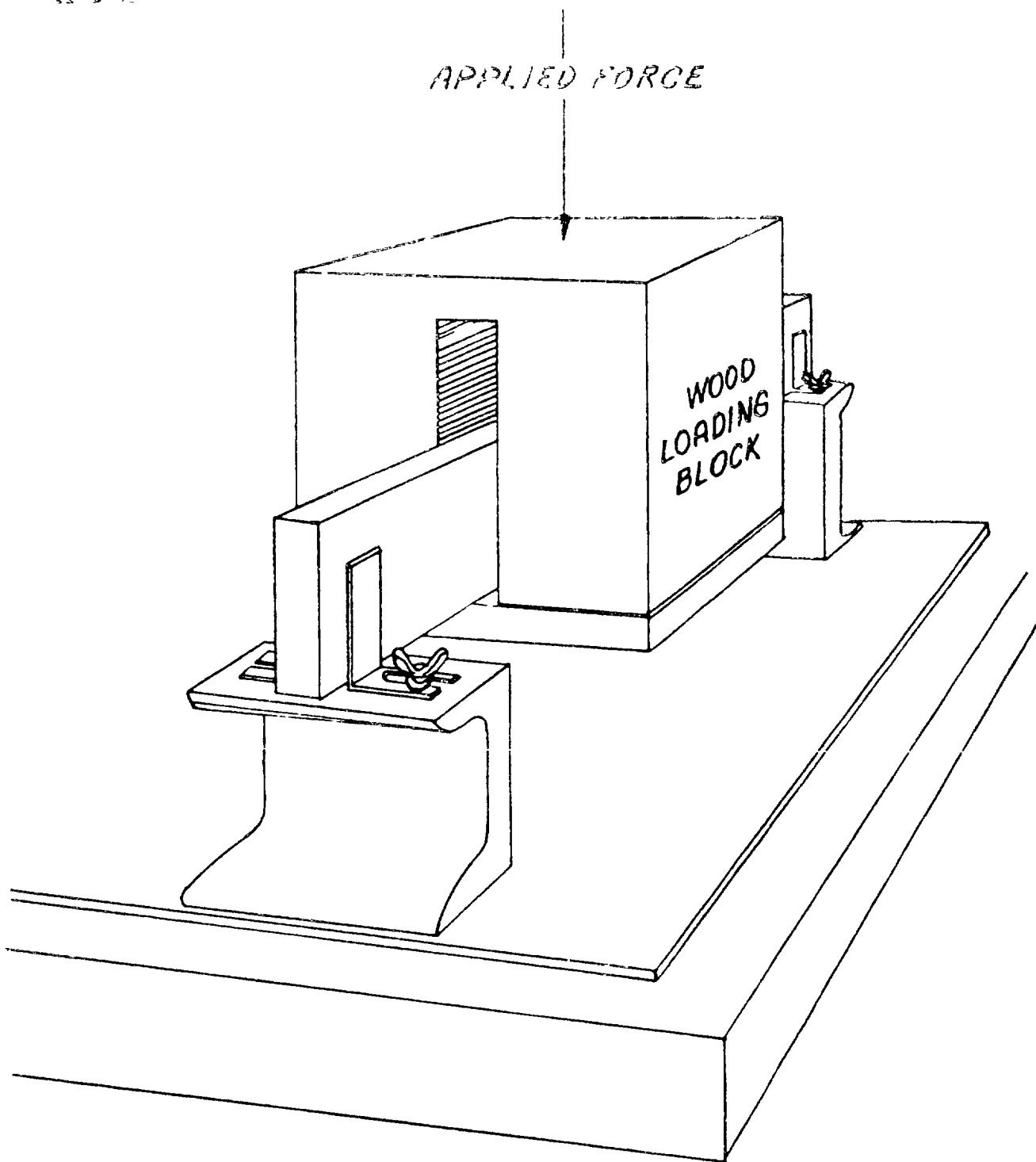

FIGURE 17. TEST FIXTURE FOR DIRECT WITHDRAWAL RESISTANCE TEST
(PARAGRAPH 4.3.2.3.2)

PPP-2 5210

MILITARY OPERATIONS:

Custodians:

Army - GL
Navy - SA
Air Force - 69

Review Activities:

Army - ME, SM, MC, MT, AR, MD
Navy - AS, YD
Air Force - 99

User Activities:

Navy MC, OS, SH

CIVIL POLICY COORDINATING ACTIVITIES:

GSA - FSC
USDA - APS

PREPARING ACTIVITY:

Army - GL

Project No. 8115-0440

U.S. GOVERNMENT PRINTING OFFICE : 1982 - 361-705/1310

Orders for this publication are to be placed with General Services Administration, acting as an agent for the Superintendent of Documents. See section 2 of this specification to obtain extra copies and other documents referenced herein.

INSTRUCTIONS In a continuing effort to make our standardization documents better, the DoD provides this form for users to submit comments and suggestions for improvements. All users of military standardization documents are invited to provide suggestions. This form may be detached, folded along the lines indicated, taped along the loose edge (DO NOT STAPLE) and mailed. In block 6, be as specific as possible about particular problem areas such as wording which requires interpretation, was too rigid, restrictive, loose, ambiguous, or was too general, and give proposed wording changes which would alleviate the problems. Enter in block 8 any remarks not related to a specific paragraph of the document. If block 7 is filled out, an acknowledgment will be mailed to you within 30 days to let you know that your comments were received and are being considered.

NOTE This form may not be used to request copies of documents, nor to request waivers, deviations, or clarification of specification requirements on current contracts. Comments submitted on this form do not constitute or imply authorization to waive any portion of the referenced document(s) or to amend contractual requirements.

(Fold along this line)

(Fold along this line)

DEPARTMENT OF THE AIR FORCE



NO POSTAGE
NECESSARY
IF MAILED
IN THE
UNITED STATES

OFFICIAL BUSINESS
PENALTY FOR PRIVATE USE \$300

BUSINESS REPLY MAIL
FIRST CLASS PERMIT NO 73236 WASHINGTON D C

POSTAGE WILL BE PAID BY THE DEPARTMENT OF THE AIR FORCE

AFALD/PTR
WRIGHT-PATTERSON AFB, OH 45433

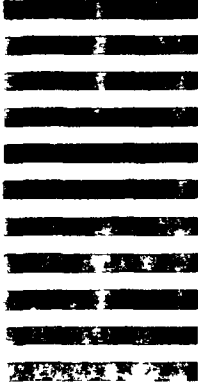

STANDARDIZATION DOCUMENT IMPROVEMENT PROPOSAL

(See Instructions - Reverse Side)

1 DOCUMENT NUMBER		2 DOCUMENT TITLE	
3a NAME OF SUBMITTING ORGANIZATION		4 TYPE OF ORGANIZATION (Mark one)	
b ADDRESS (Street, City, State, ZIP Code)		<input type="checkbox"/> VENDOR <input type="checkbox"/> USER <input type="checkbox"/> MANUFACTURER <input type="checkbox"/> OTHER (Specify) _____	
5 PROBLEM AREAS			
a. Paragraph Number and Wording			
b. Recommended Wording			
c. Reason/Rationale for Recommendation			
6 REMARKS			
7a NAME OF SUBMITTER (Last, First MI) - Optional		b WORK TELEPHONE NUMBER (Include Area Code) - Optional	
c MAILING ADDRESS (Street, City, State, ZIP Code) - Optional		8 DATE OF SUBMISSION (YYMMDD)	